

"C"

Dual Fuel

Dual fuel ranges

Dual Fuel 30" / 36" Convection Ranges-----	C001
(Dual Fuel Update—June 2001)-----	C001A
Dual Fuel 48" Convection Ranges -----	C002
(Dual Fuel Update---June 2001)-----	C002A
Wiring Diagram Dual Fuel 30" / 36" Con. Ranges-----	C003
Wiring Diagram Dual Fuel 48" Con. Ranges -----	C004
Dual Fuel Bake-----	C005
Convection Bake-----	C006
Convection Cook-----	C007
Mini Broil-----	C008
Maxi Broil-----	C009
Convection Broil-----	C010
Control Circuit Board-----	C011
Initiate until Door Lock-----	C012
Door Lock Below 575° F. -----	C013
Door Lock Above 575° F. -----	C014
Clean Finish Door Lock Above 575°F--	C015
Clean Finish Door Lock Below 575°F--	C016
Dual Fuel 30" / 36" with Pre-Heat-----	C017
Bake with Preheat-----	C018
Convection Bake with Preheat-----	C019
Convection Cook with Preheat-----	C020
Mini-Broil with Preheat-----	C021
Maxi-Broil with Preheat-----	C022
Convection Broil with Preheat-----	C023
Self-Clean with Preheat-----	C024
Initiate Self-Clean until Door Lock with Preheat-----	C025
Door Lock Below 575° F with Preheat-----	C026
Door Lock Above 575° F with Preheat -----	C027
Clean Finish Door Lock Above 575° F with Preheat-----	C028
Clean Finish Door Lock below 575° F with Preheat-----	C029
Pre-Heat VDSC 01-----	C030
Pre-Heat VDSC 02-----	C031
Pre-Heat VDSC 03-----	C032

(BEFORE JUNE 2001)

VDCS305 / 365 DUAL FUEL SELF-CLEAN

8 POSITION SELECTOR SWITCH

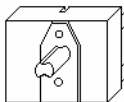
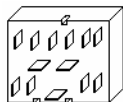
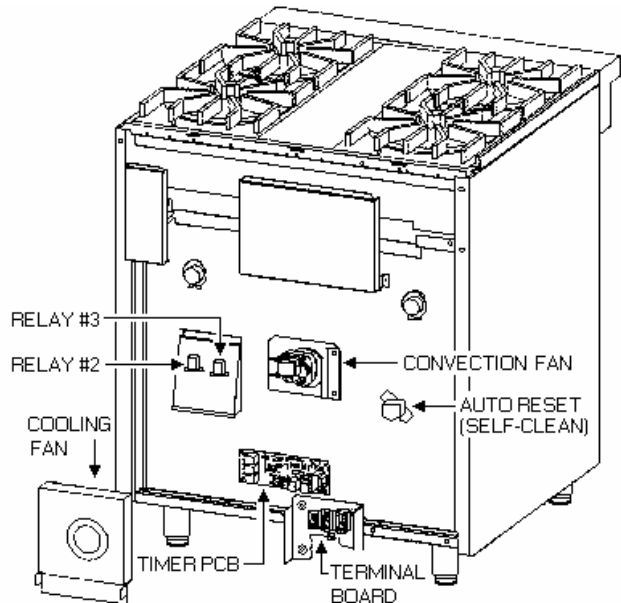
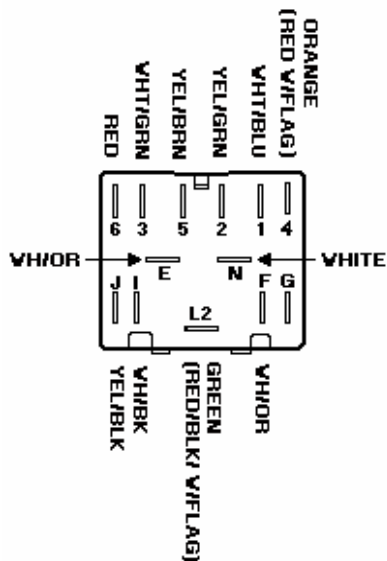

OFF



BAKE

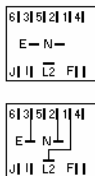

CONVECTION
BAKE



CONVECTION
COOK



BROIL



MAXI
BROIL



CONVECTION
BROIL



SELF
CLEAN

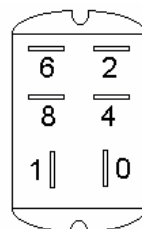

RELAY #1
Terminal Layout

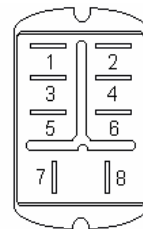

RELAY #2
Terminal Layout

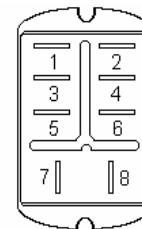

RELAY #3
Terminal Layout

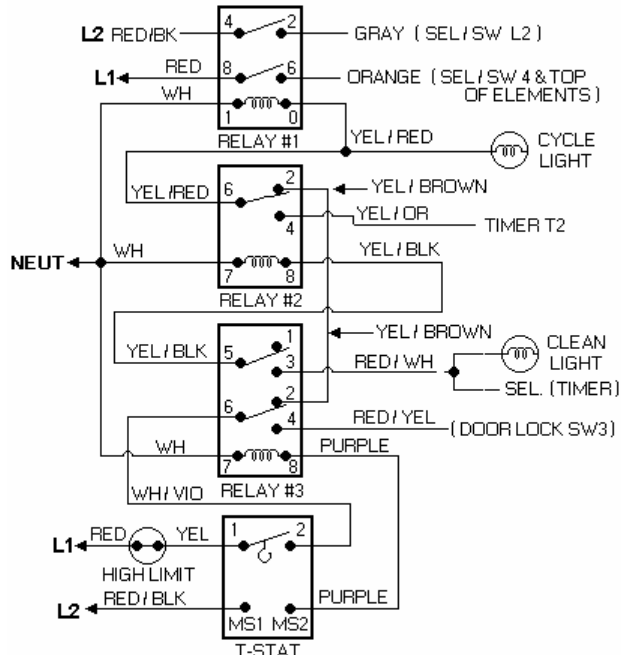

Viking Preferred Service
 Tech - Notes
VDSC305 / 365 DUAL FUEL
 Relay location and wiring connections

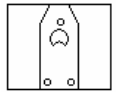
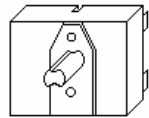
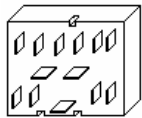
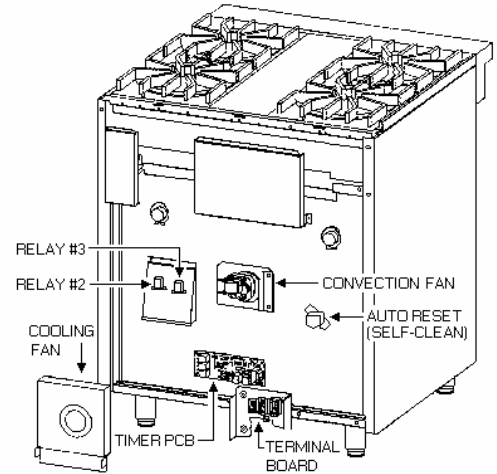
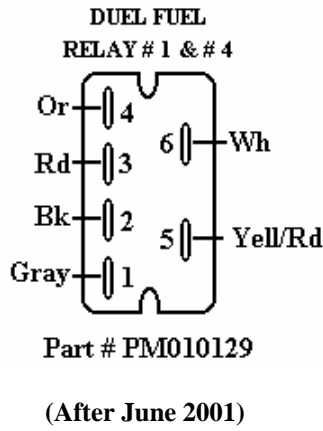
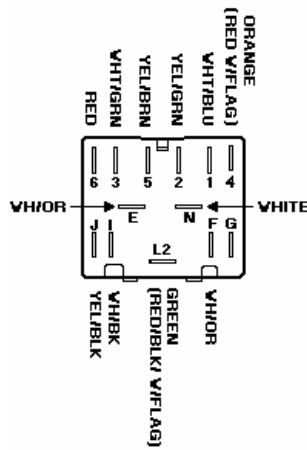

OFF

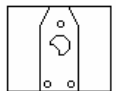
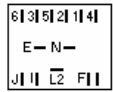

BAKE

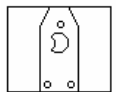
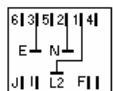

CONVECTION
 BAKE

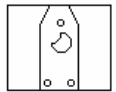
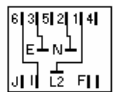

CONVECTION
 COOK

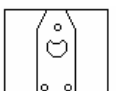
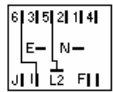

BROIL

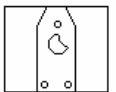
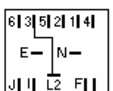

MAXI
 BROIL

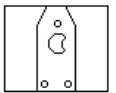
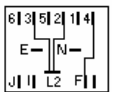

CONVECTION
 BROIL

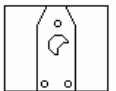
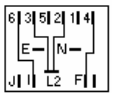

SELF
 CLEAN

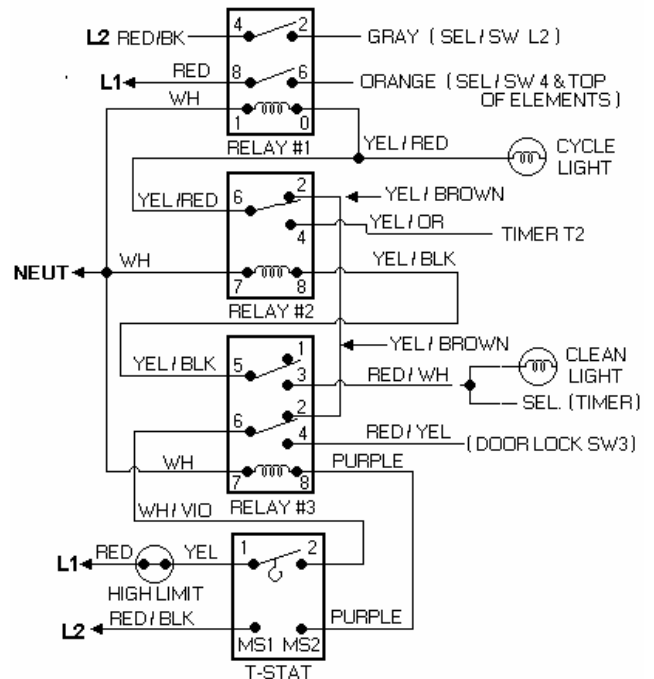
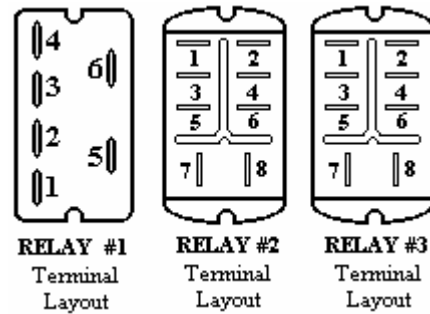
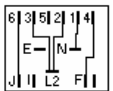

BEFORE JUNE 2001

VDSC485 DUAL FUEL SELF-CLEAN

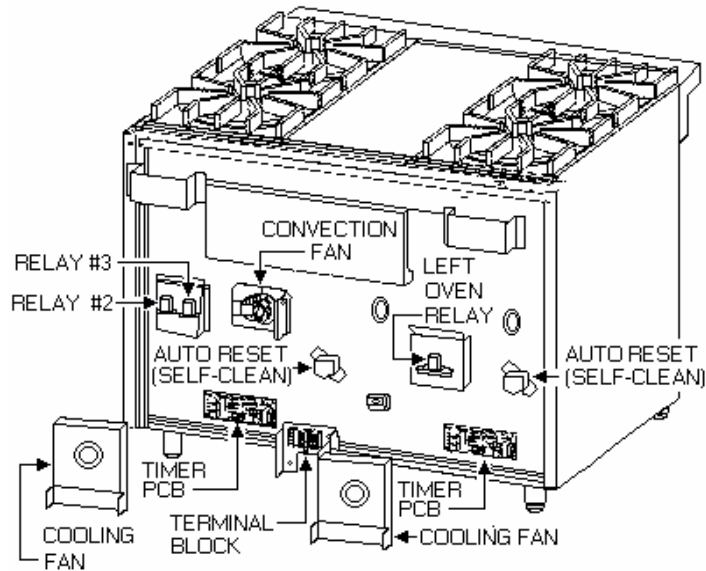

VDSC485 DUEL FUEL
Relay location and wiring connection

RIGHT HAND OVEN

LEFT HAND OVEN

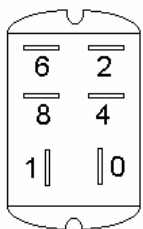

RELAY #1
Terminal Layout

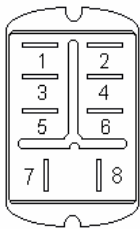

RELAY #2
Terminal Layout

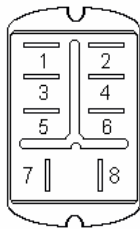

RELAY #3
Terminal Layout

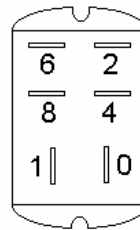

RELAY #4
Terminal Layout

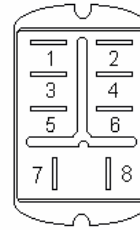

RELAY #5
Terminal Layout

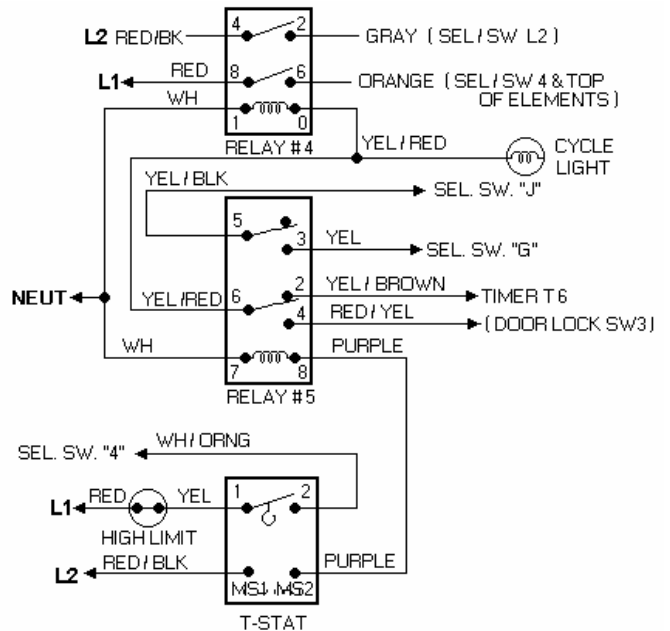
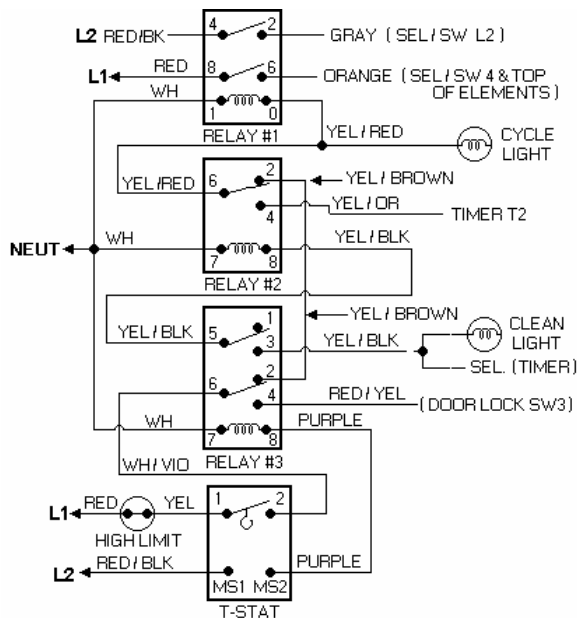

Viking Preferred Service Tech - Notes

VDSC485 DUAL FUEL SELF-CLEAN

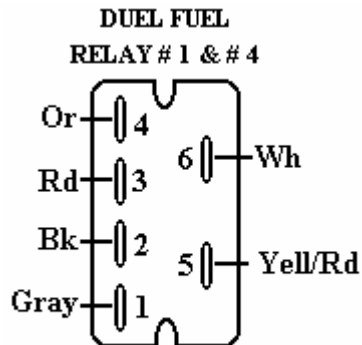
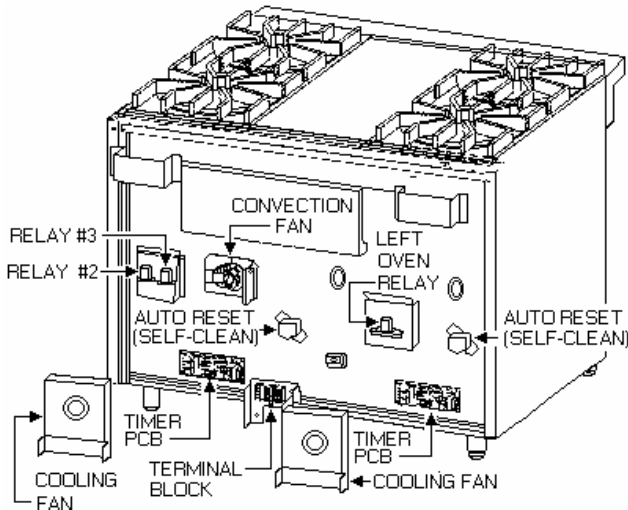

Part # PM010129

(After June 2001)

Relay location and wiring connections

RIGHT HAND OVEN

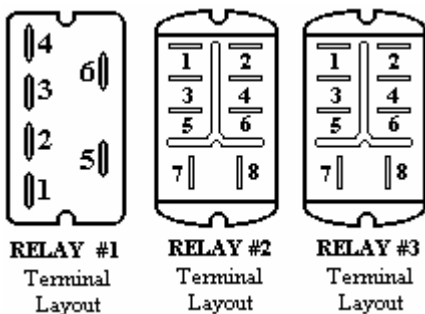

LEFT HAND OVEN

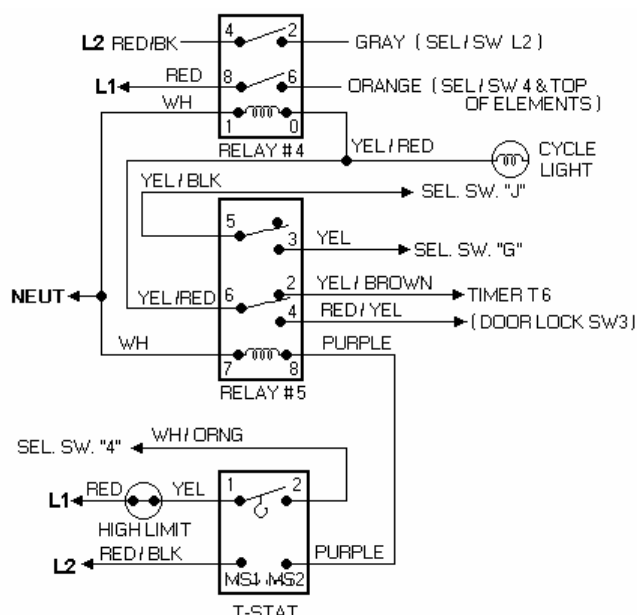
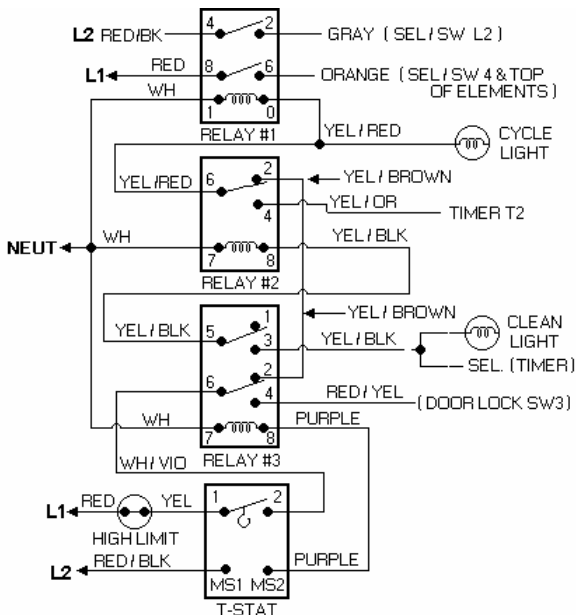
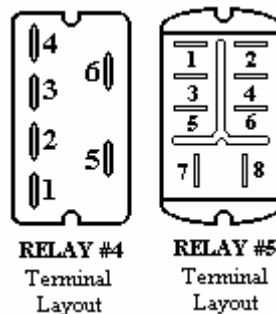

WIRING DIAGRAM DUAL FUEL 30" W & 36" W CONVECTION RANGES

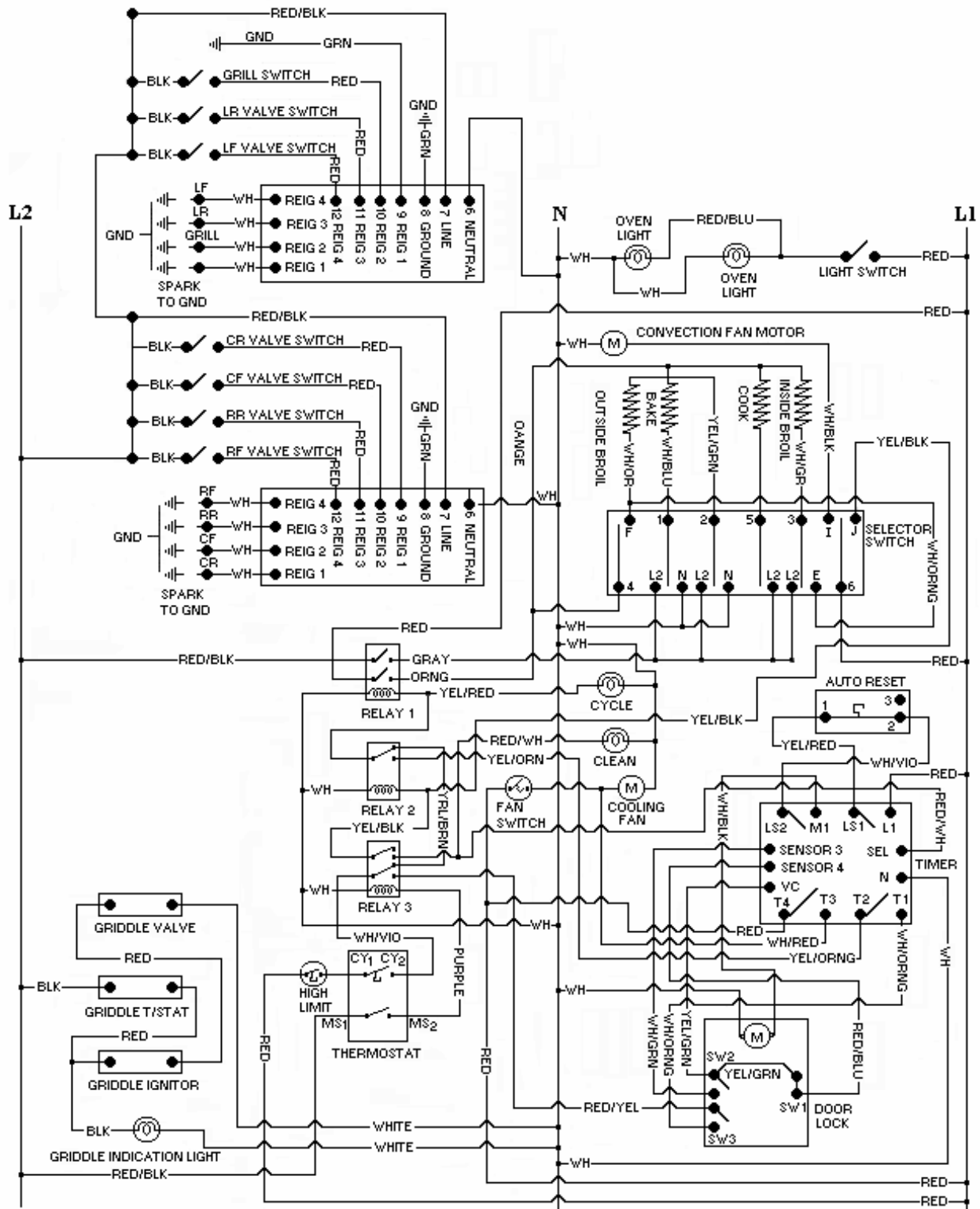

WIRING DIAGRAM DUAL FUEL 48" W. CONVECTION RANGES

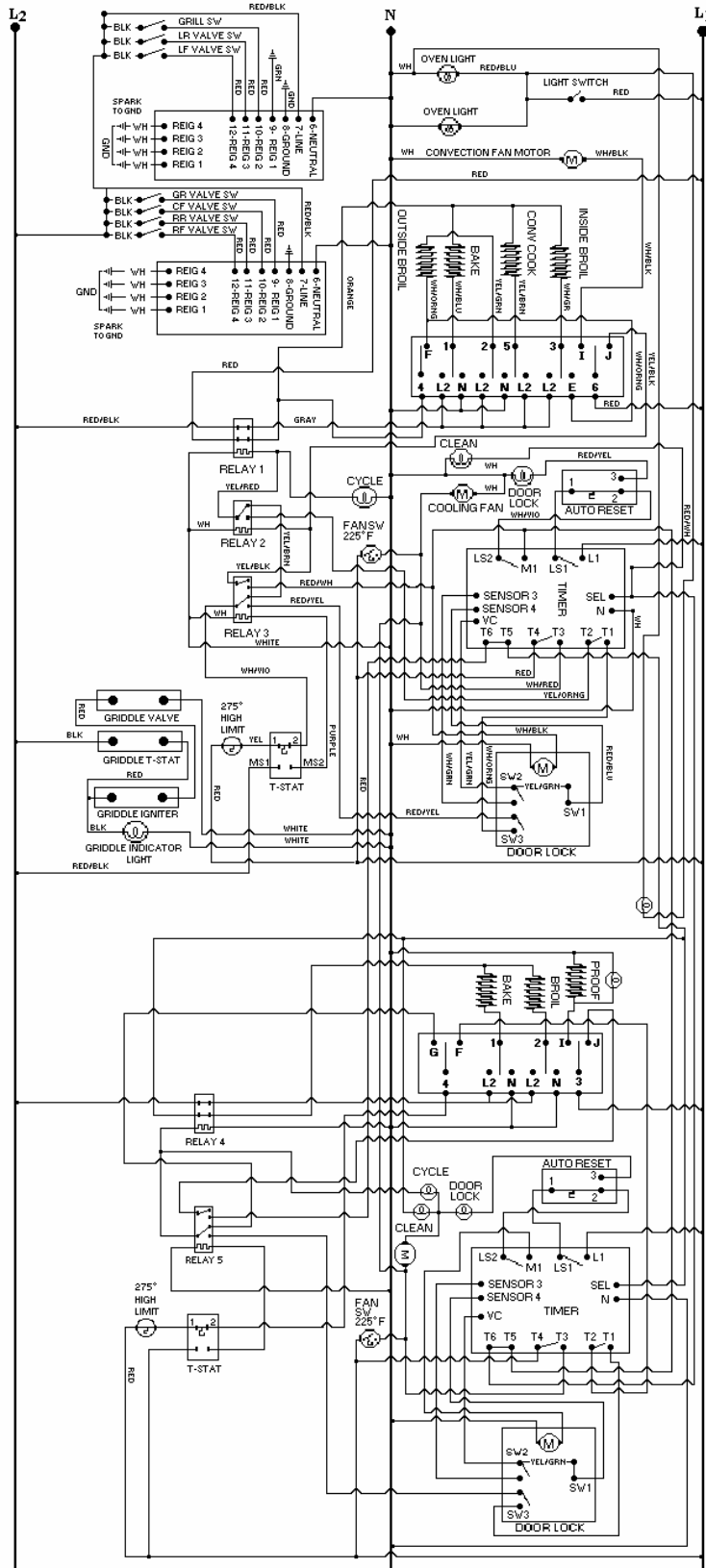

WIRING DIAGRAM DUAL FUEL BAKE

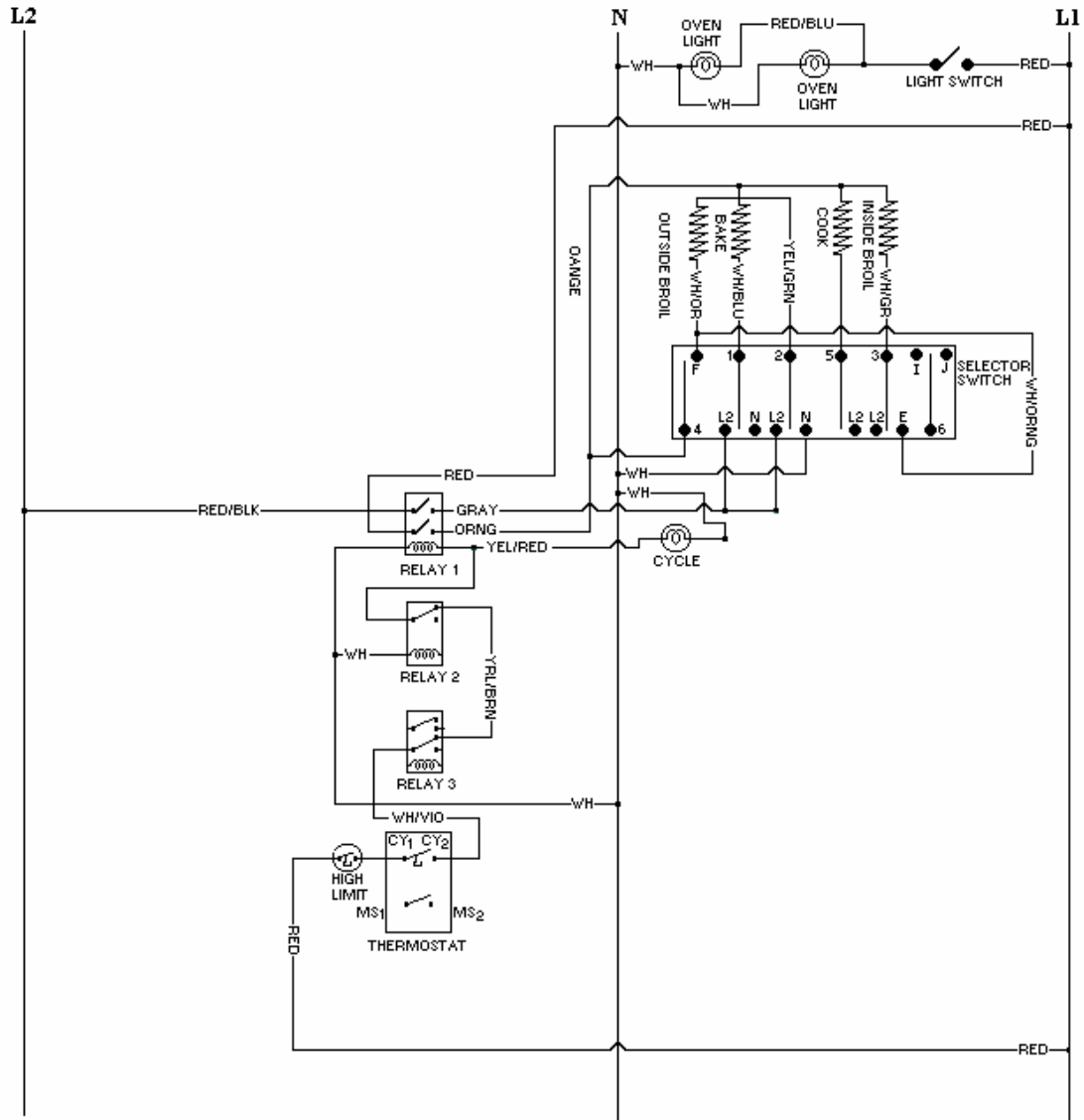

Selector Bake position closes Switches 1 – L2, 2 – N, and 3 – E. The thermostat closes Switches Cy1 – Cy2, which cycles with the oven temperature powering Relay 1 and the Oven Cycle Light. When Relay 1 closes, it powers the Bake Element at 208 / 240V, and with the Broil Element in series across a 120V circuit, powers the inside Broil Element at 70V and the Outside Broil Element at 50V.

WIRING DIAGRAM DUAL FUEL CONVECTION BAKE

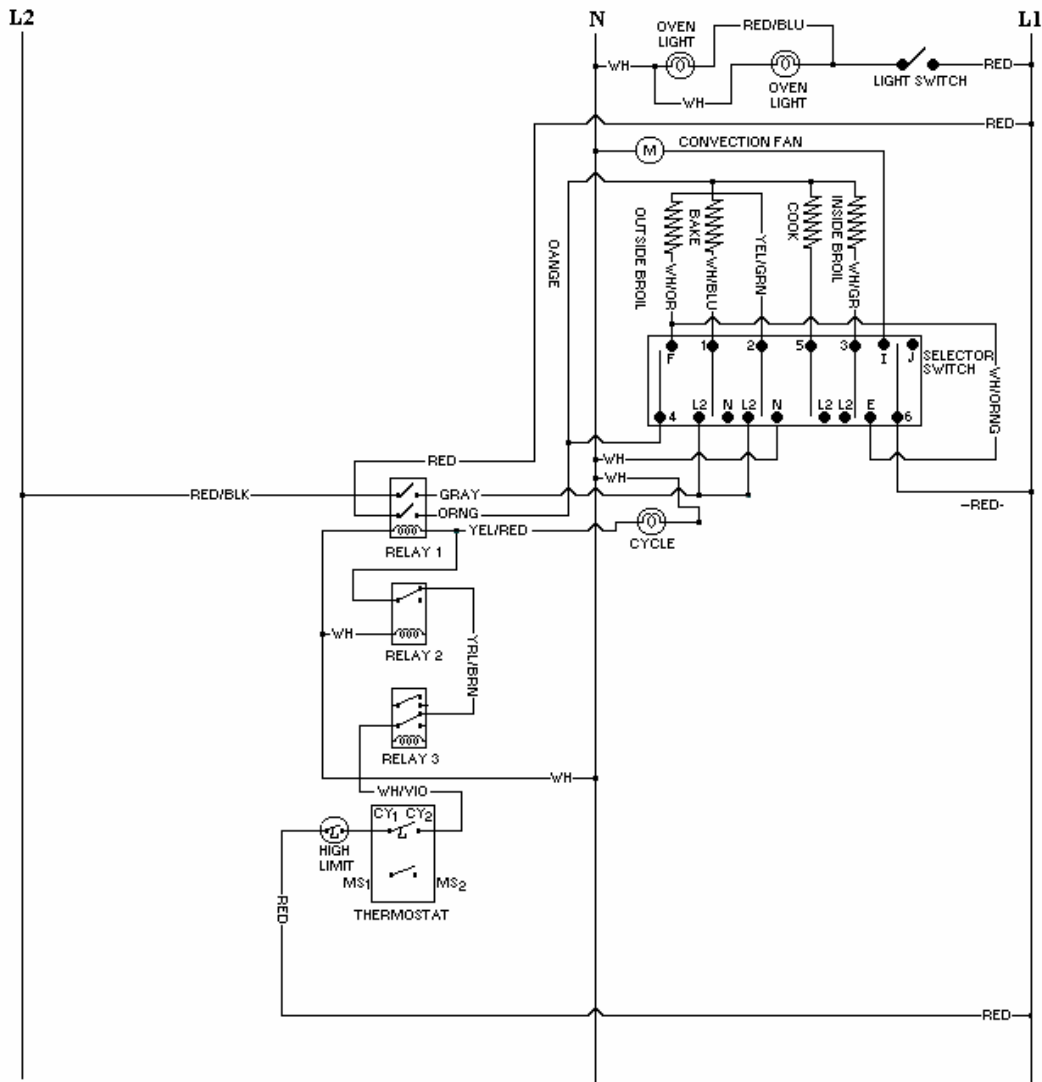

Selector Convection Bake position closes Switches 1 – L2, 2 – N, 3 – E, and 6 – I, 6 – I powers the Convection Fan through L1 at 120V. The Thermostat closes Switches Cy1 – Cy2, which cycles with the oven temperature powering Relay1 and the Oven Cycle Light. When Relay 1 closes, it powers the Bake Element at 208 / 240V, and with the Broil Elements in series across a 120V circuit, it powers the Inside Broil Element at 70V and the Outside Broil Element at 50V.

WIRING DIAGRAM DUAL FUEL CONVECTION COOK

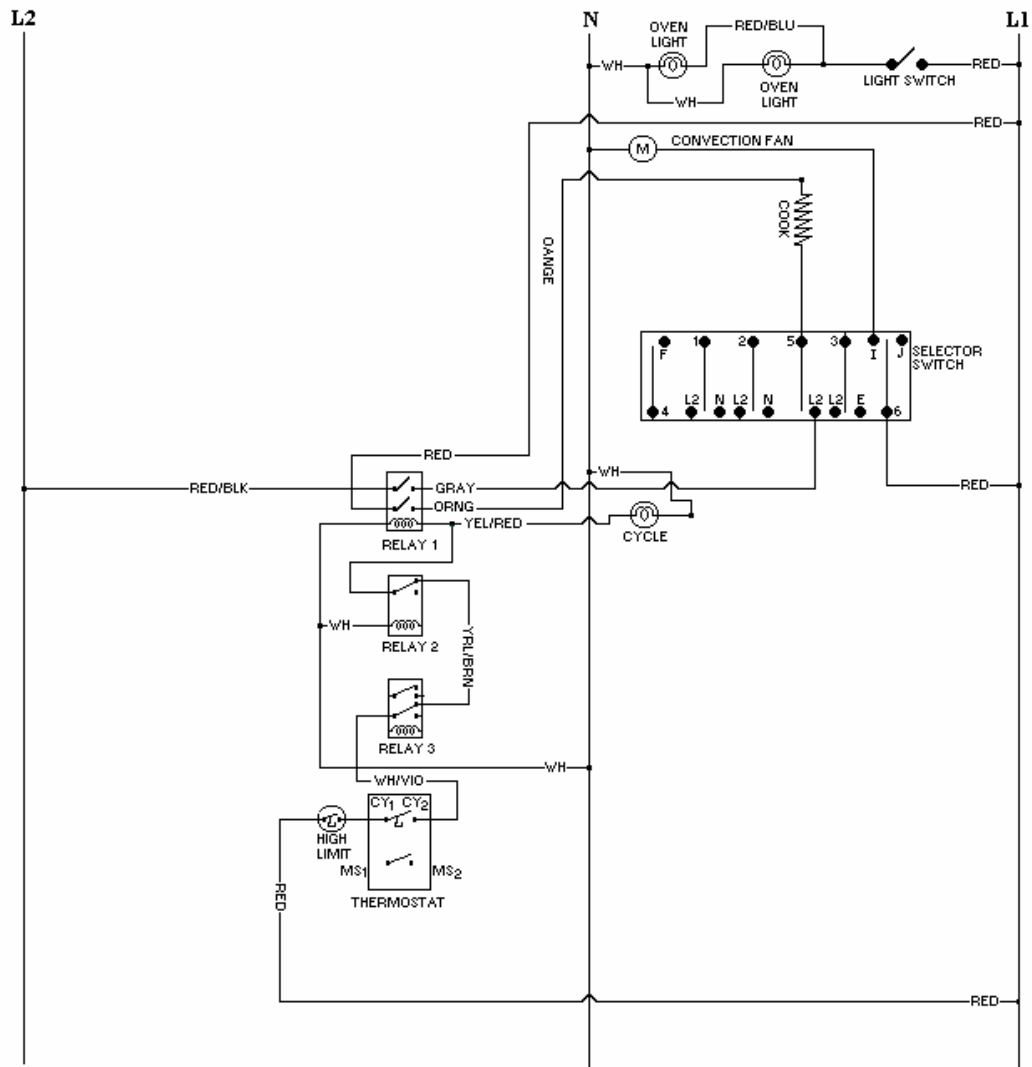

Selector Convection Cook position closes Switches 5 – L2, and 6 – 1, 6 – 1 powers the Convection Fan through L1 at 120V. The Thermostat closes Switch Cy1 – Cy2, which cycles with the Oven Temperature, powering Relay1 and the Oven Cycle Light. When Relay 1 closes, it powers the Convection Element at 208 / 240V.

WIRING DIAGRAM DUAL FUEL MINI BROIL

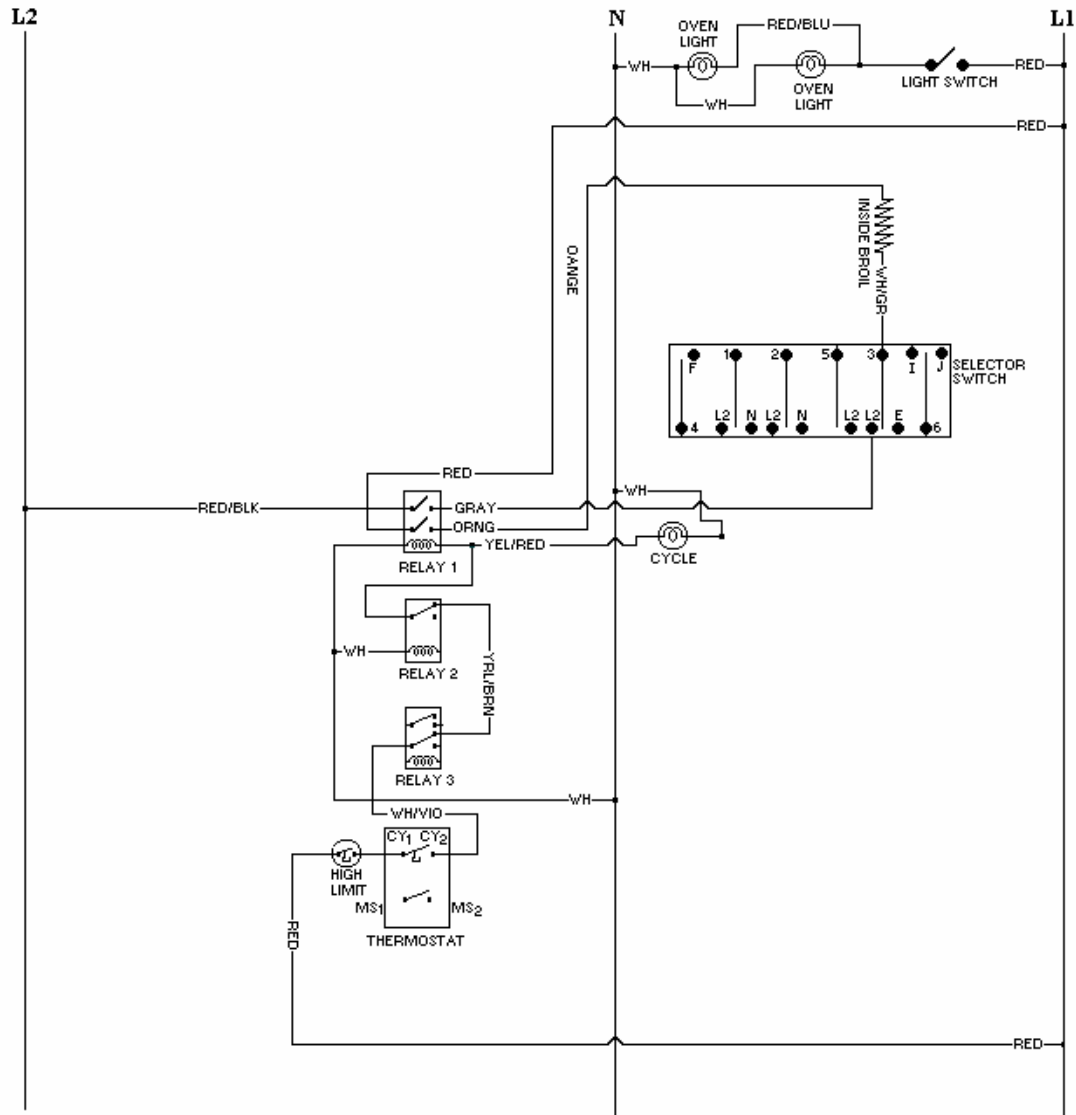

Selector Mini Broil position closes Switches 3 – L2. The Thermostat closes Switch Cy1 – Cy2, powering Relay 1 and the Oven Cycle Light. When Relay 1 closes, it powers the Inside Broil Element at 208 / 240V.

WIRING DIAGRAM DUAL FUEL MAXI BROIL

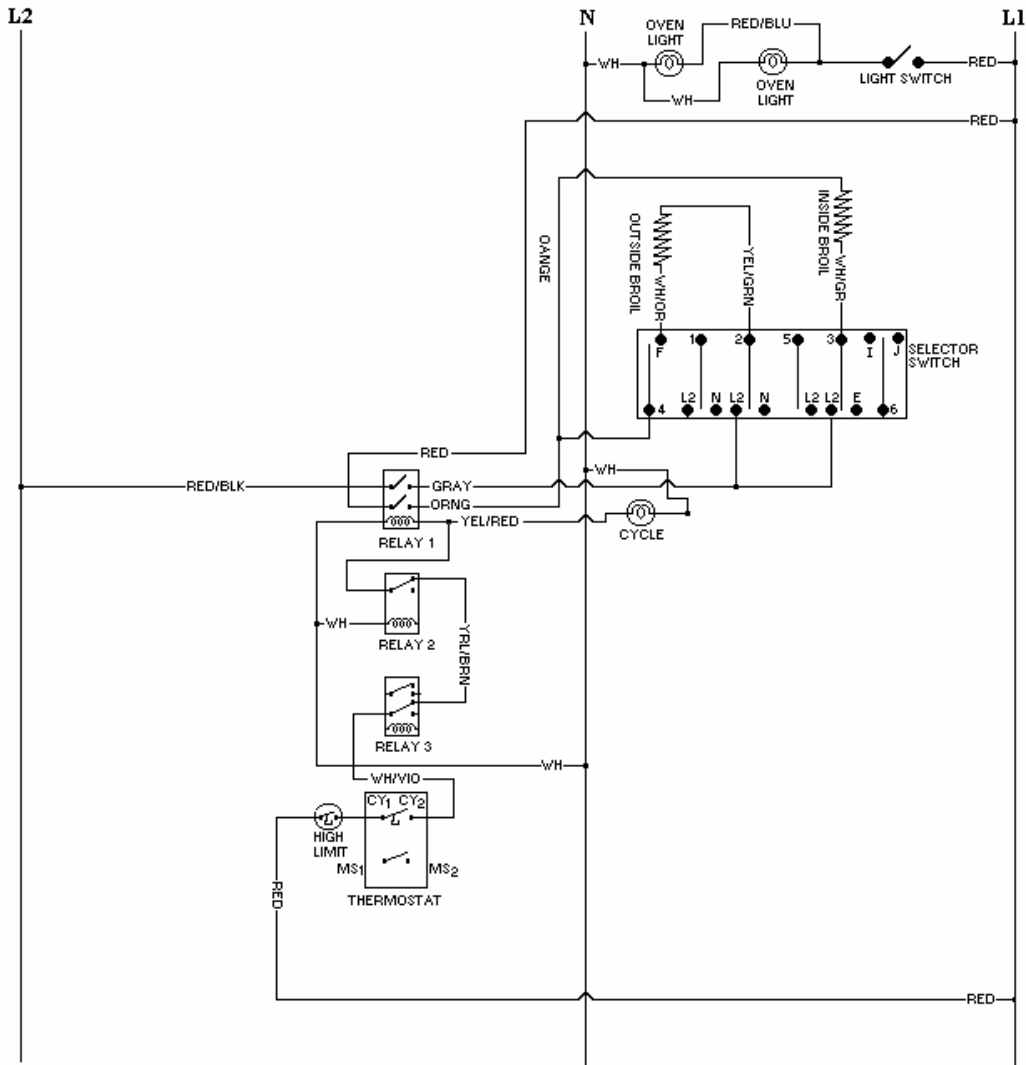

Selector Maxi Broil position closes Switches 4 – F, 2 – L2, and 3 – L2. The Thermostat closes Switch Cy1 – Cy2, which cycles with the Oven Temperature, powering Relay 1 and the Oven Cycle Light. When Relay 1 closes, it powers the Inside Broil Element at 208 / 240V and the Outside Broil Element at 208 / 240V.

WIRING DIAGRAM DUAL FUEL CONVECTION BROIL

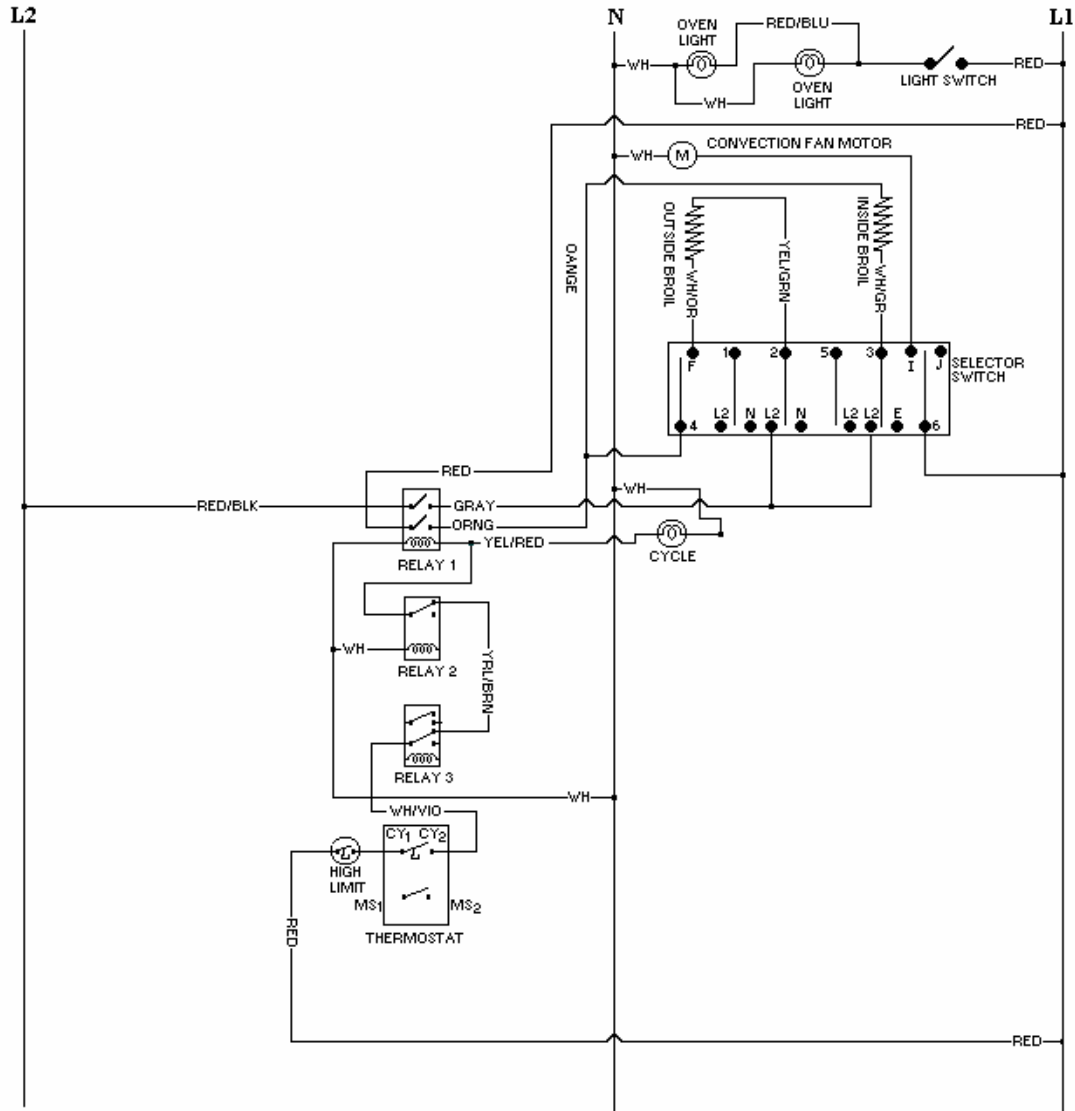

Selector Convection Broil position closes Switches 4 – F, 2 – L2, 3 – L2, and 6 – I. 6 – I powers the Convection Fan through L1 at 120V. The Thermostat closes Switches Cy1 – Cy2, which cycles with the Oven Temperature, powering Relay 1 and the Oven Cycle Light. When Relay 2 closes it powers the Inside Broil Element at 209 / 240V and the Outside Broil Element at 208 / 240V.

**WIRING DIAGRAM
DUAL FUEL SELF-CLEAN**

CLEAN DOOR LOCK BELOW 575°F ± 25°F

SELECTOR SWITCH closes Heating Element contacts 4 – F, 1 – N, 2 – L2, 3 – L2 and Door Lock Module / Timer contacts J – 6 energizing Relay #2.

THERMOSTAT CLEAN POSITION closes Thermostat cycling contacts 1 – 2 and normally open (N) – common © energizing Relay #3.

RELAY #3 turns on the clean indicator Light and energizes Door Lock Module / Timer (PC board) Relays LS1 – L1 and LS2 – M1, also supplying 120VAC to SEL on the PC board.

RELAYS LS1 and LS2 turns the door Lock Motor on through the Auto Reset Thermostat contacts 2 – 1.

DOOR LOCK MOTOR rotates opening SW1 and closing SW3.

DOOR LOCK SWITCH #2 completes the circuit to sensor #3 on the PC board. After 10 seconds LS1 – M1 opens, stopping the Door Lock motion.

DOOR LOCK SWITCH #3 closes T1 – T2 and T3 – T4 energizing Power Relay #1 and the cooling Fan. Closing Power Relay #1's contacts supplies 240VAC to both Broil Elements and 120vac to the Bake Element.

CLEAN DOOR LOCK ABOVE 575°F ± 25°F

AUTO RESET THERMOSTAT switches to contacts 1 – 3 turning on the Door Lock indicator Light and disables the Door Lock Motor circuit.

CLEAN TEMPERATURE (875°F) REACHED

DOOR LOCK MODULE / TIMER opens T3 – T4 and T1 – T2 turning off the cooling Fan, now powered by the Fan Limit Switch when needed, and opens the circuit to the Power Relay #1 disabling the Heating Elements.

FINAL BELOW 575°F ± 25°F

AUTO RESET THERMOSTAT switches to contacts 1 – 2, turning off the Door Lock Motor circuit through Door Lock Motor / Time Relay LS2 – M1. Door Lock Motor operates until 2 seconds after sensor 4 is signaled by VC that the Door Lock switch SW1 has been closed mechanically by the Door Lock Bolt. The Door Lock / Timer switches LS2 – M1 and LS2 – L1 open and the timer resets.

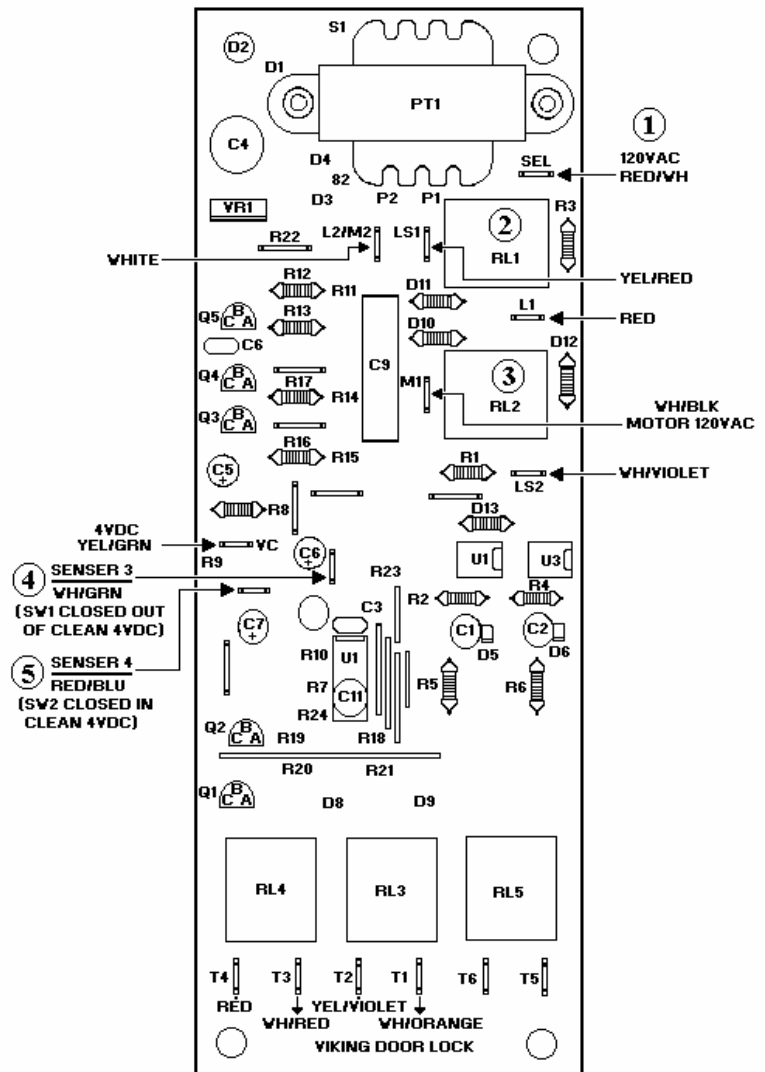

CONTROL CIRCUIT BOARD

**WIRING DIAGRAM
DUAL FUEL CLEAN DOOR LOCK BELOW 575°F ± 25°F**

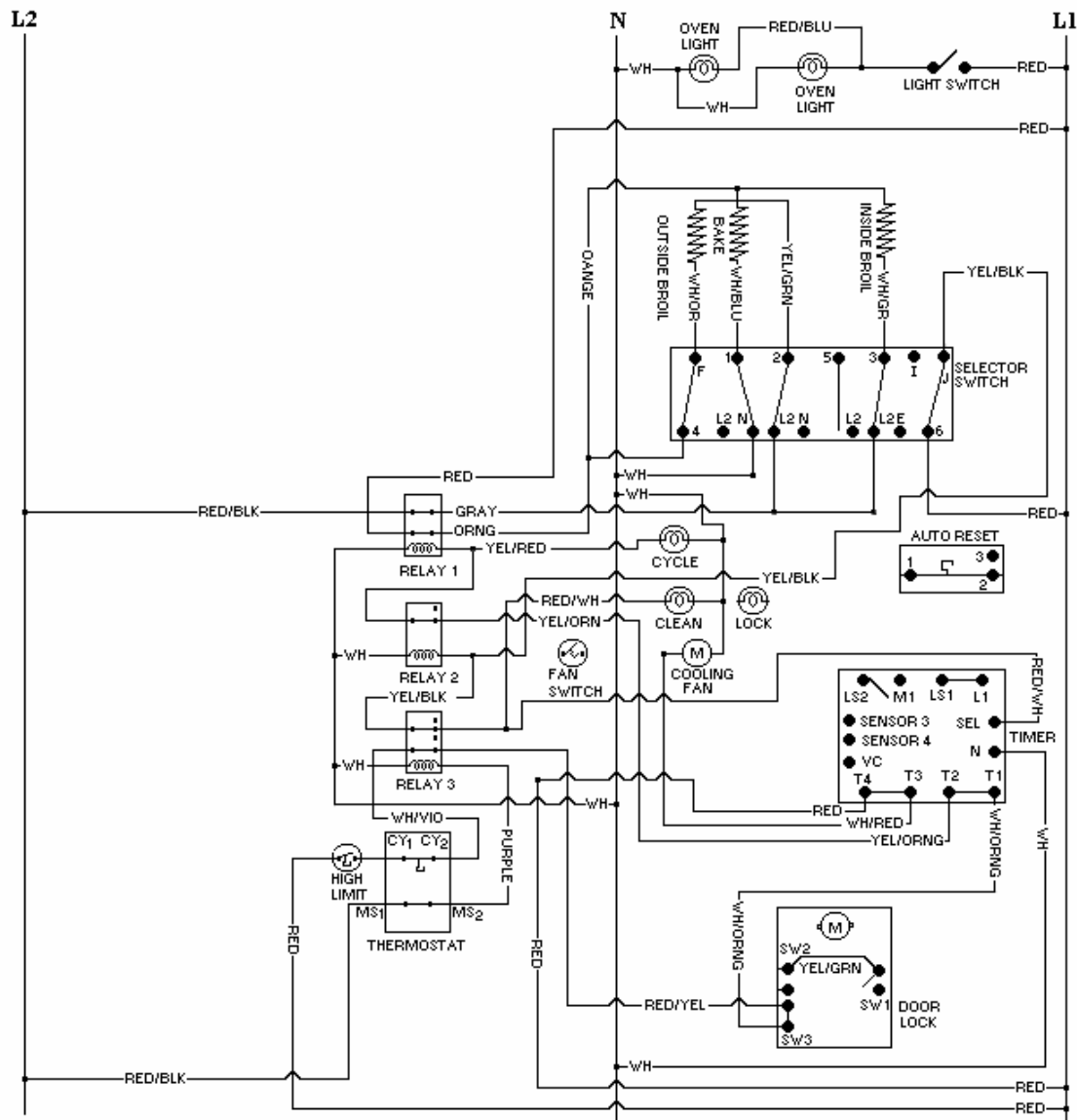

10 seconds after the signal to Sensor 3, Switch LS2 – M1 is opened, stopping the door lock motion and switches T1 – T2, and T3 – T4 which switches Relay #1, powering the Cooling Fan, which closes Relay #1 powering the Inside and Outside Broil Elements to 208V / 240V and the Bake Element to 120V.

**WIRING DIAGRAM
DUAL FUEL CLEAN DOOR LOCK ABOVE 575°F ± 25°F**

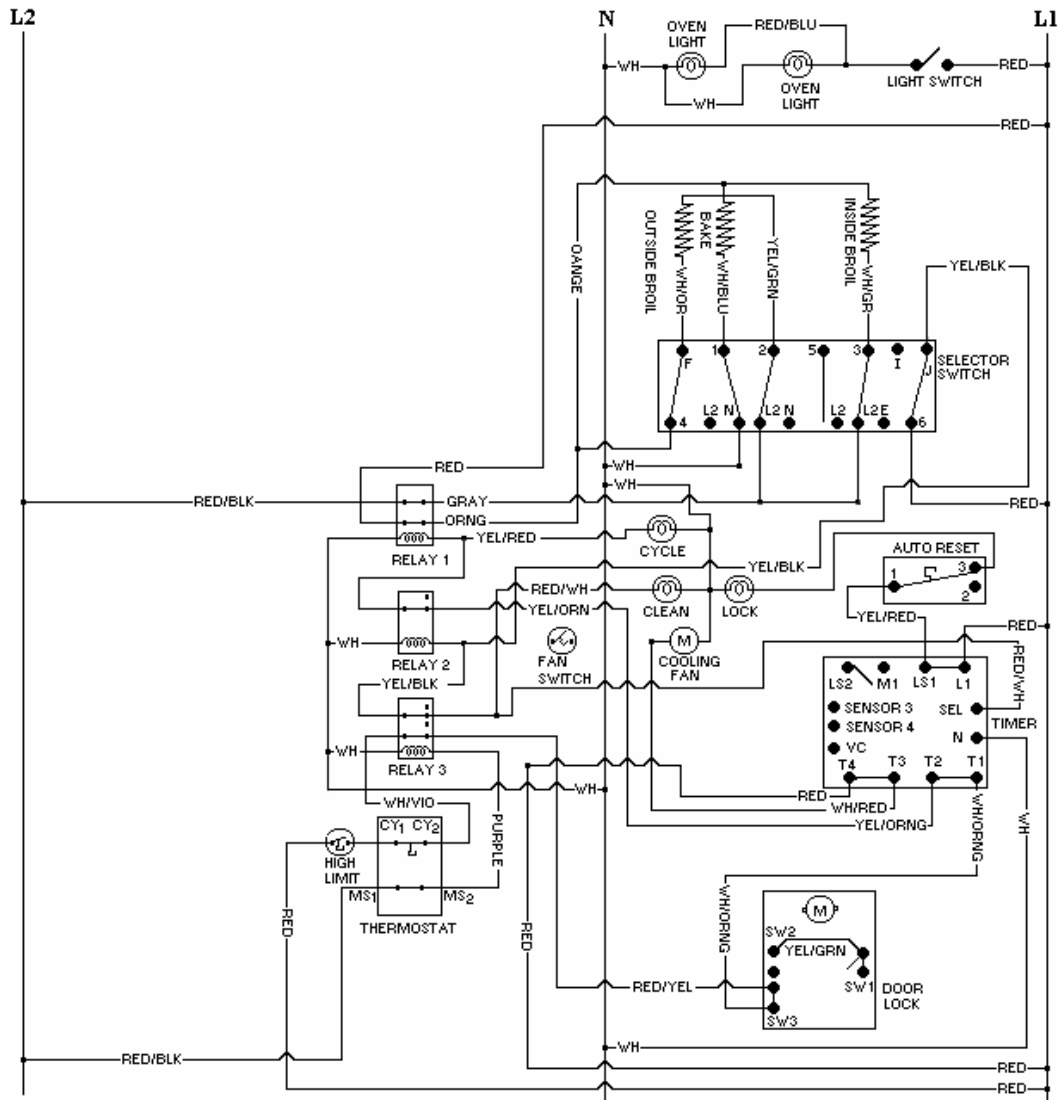

Auto Reset switches to 1 – 3 which turns Door Lock Indicator on and disables Door Lock Motor circuit.

**WIRING DIAGRAM
DUAL FUEL CLEAN FINISH DOOR LOCK ABOVE 575°F ± 25°F**

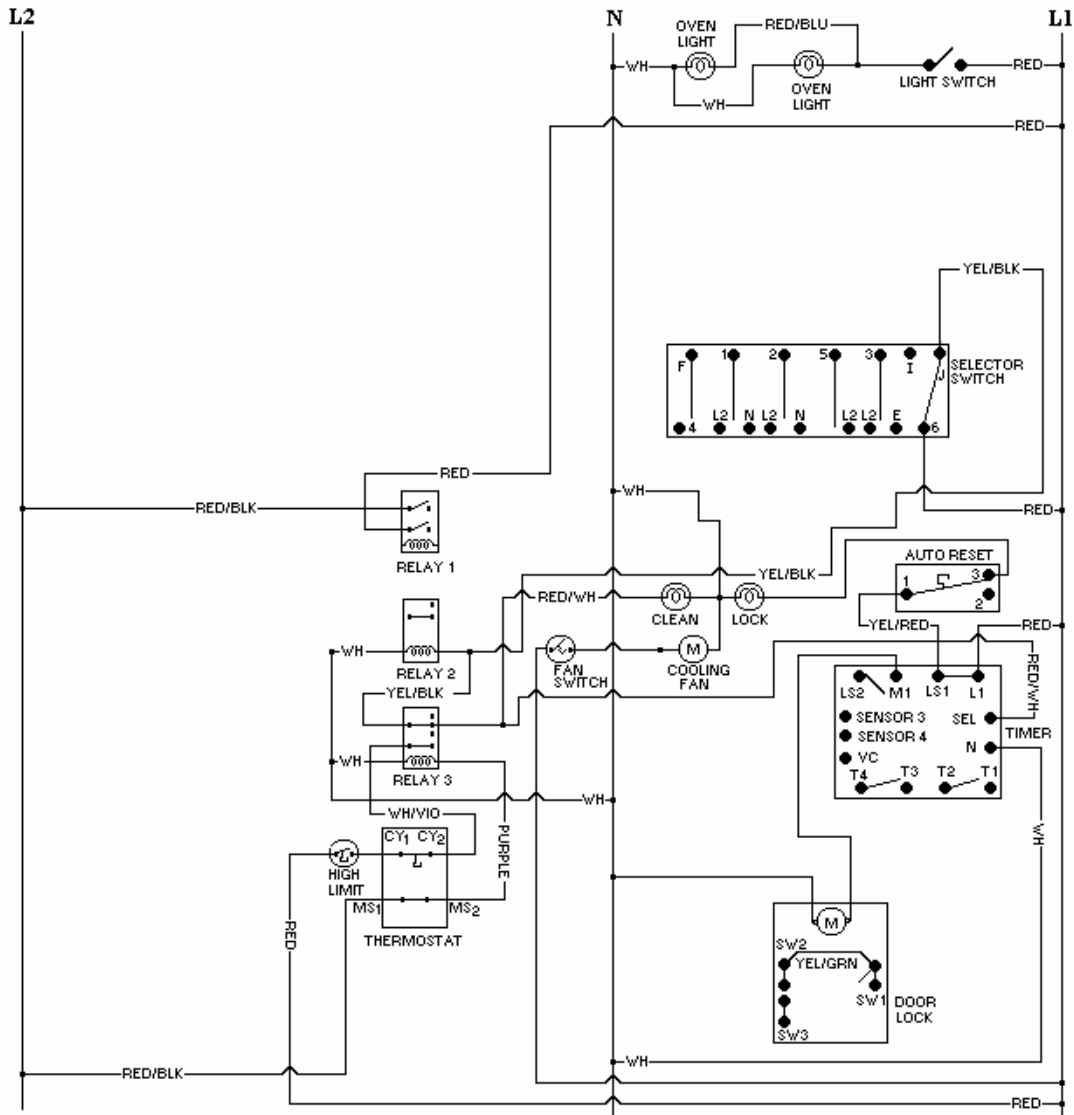

Timer Switches T3 – T4, T1 – T2, open, turning off the Cooling Fan, which will then be powered at 120V by the Fan Limit Switch when needed, and opening the circuit to Relay #1 which disables the Heating Elements. Switch LS2 – M1 closes to power the Door Lock Motor.

WIRING DIAGRAM
DUAL FUEL CLEAN FINISHED DOOR LOCK BELOW 575°F ± 25°F

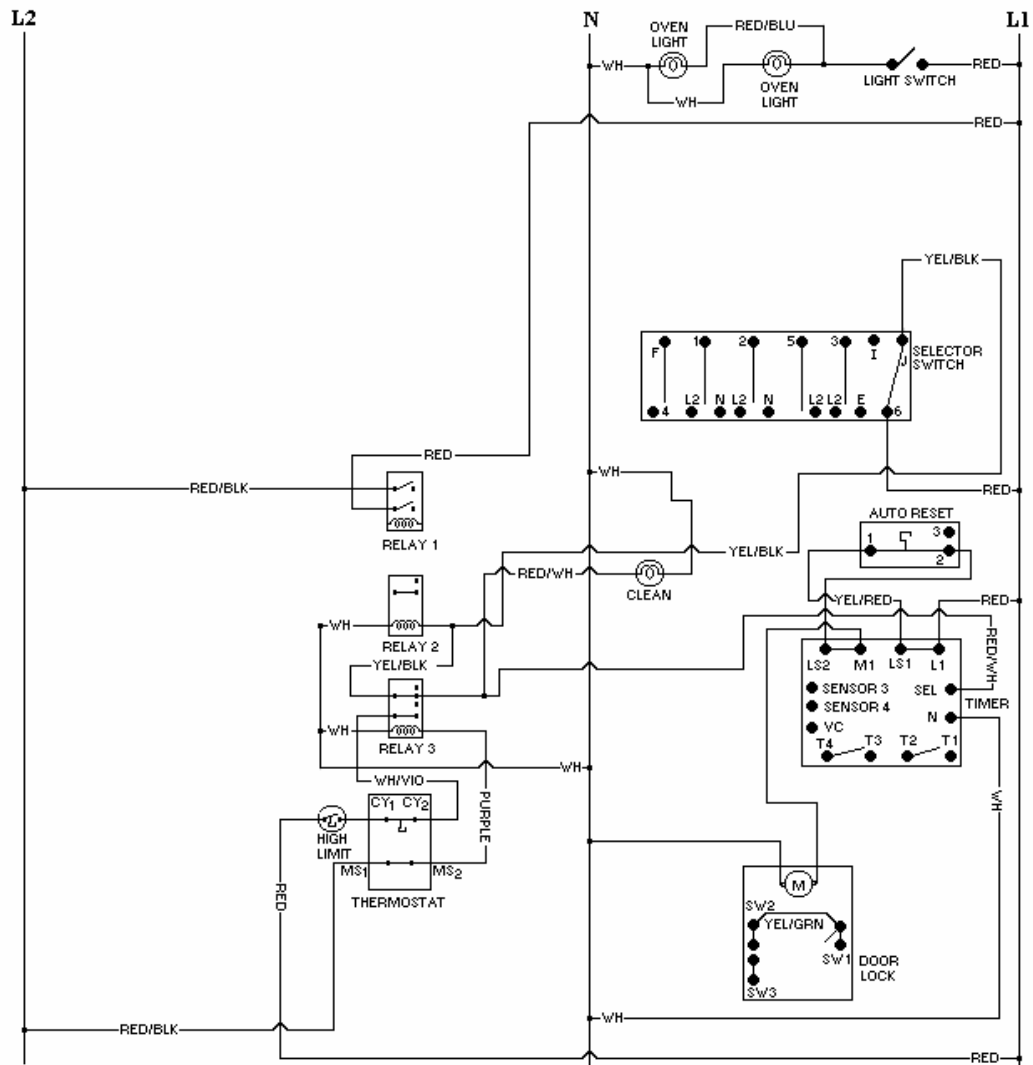

Auto Reset Switches 1 – 2 closed allowing the door Lock Motor to operate and turn the Door Lock Light off. The Door Lock Motor operates until 2 seconds after Sensor 4 is signaled by VC that the Door Lock / Timer switches LS2 – M1 and LS1 – L1 open and the Timer resets.

Dual Fuel Schematic (with Pre-Heat)

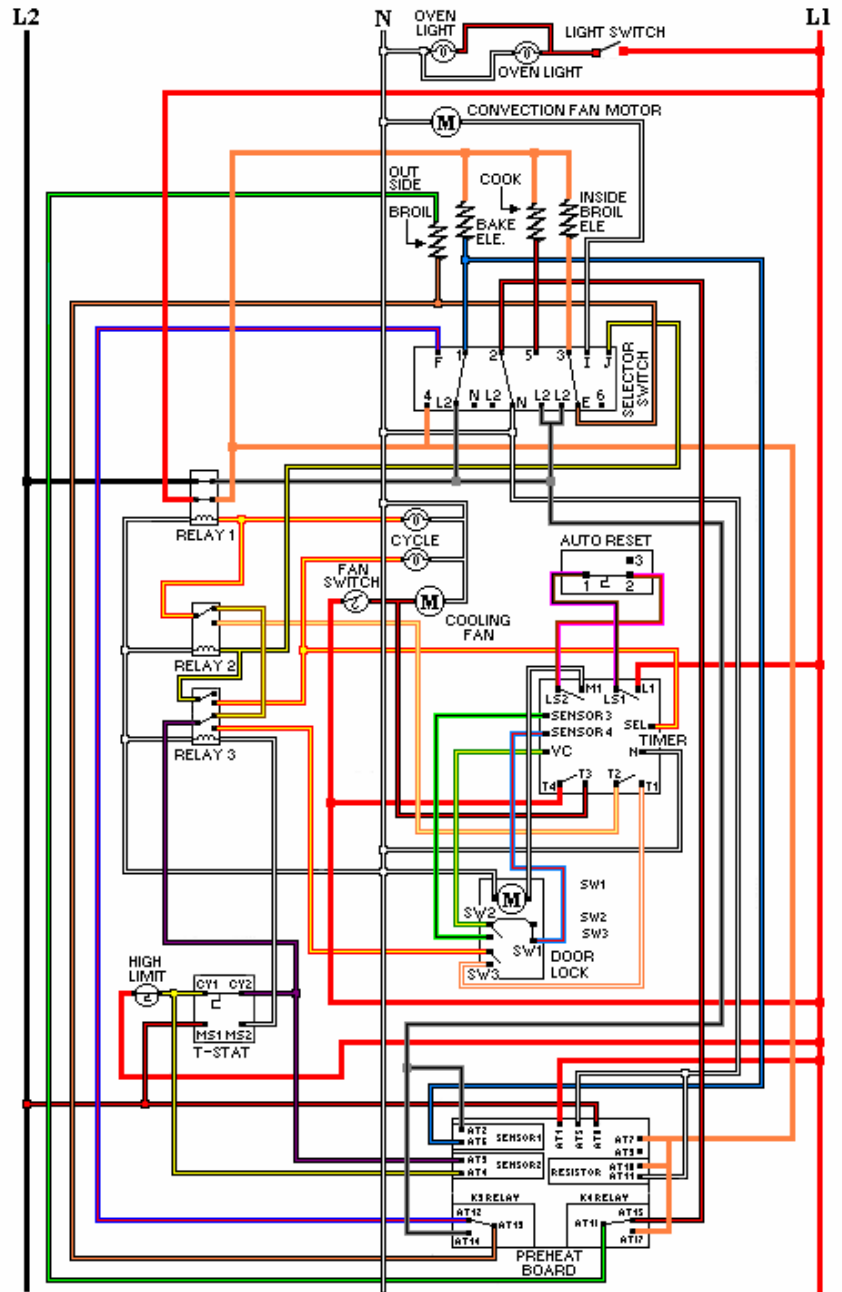
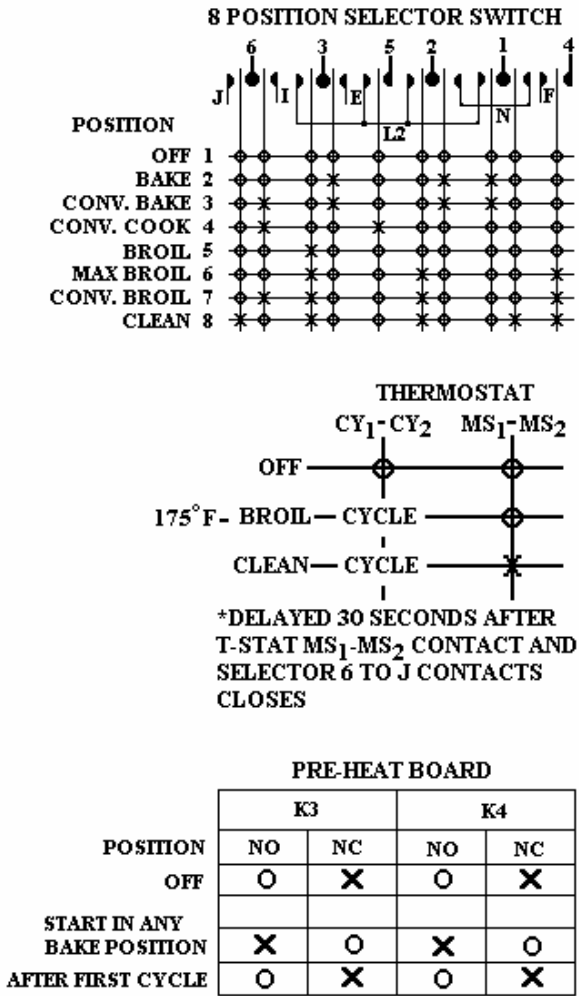

Dual Fuel Bake

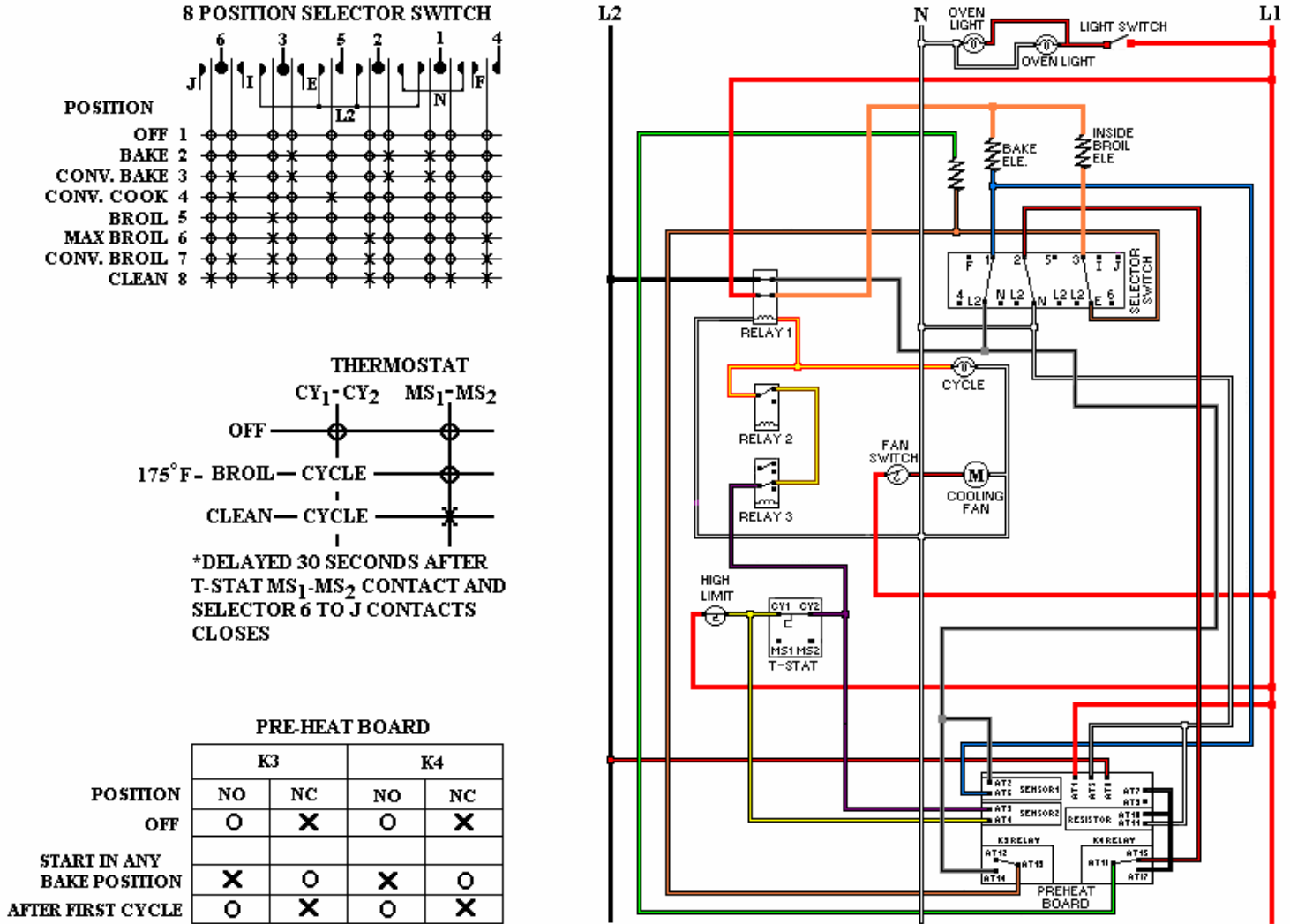

Selector in “Bake” position closes selector switch 1-L1, 2-N, and 3-E. The thermostat “on” closes switch Cy1-Cy-2, which cycles with the oven temperature powering relay 1 and the oven cycle light. When relay 1 closes on the first cycle the broil elements are powered through relay K3 AT15-AT14 and relay K4 AT16-AT15 on the preheat board at 208/240V and the bake elements is powered at 208/240V. when thermostat switch Cy1-Cy2 opens after first cycle relay K3 AT15-AT14 and relay K4 AT15-AT17 open. When thermostat switch Cy1-Cy2 closes for the second cycle relay 1 closes, it powers the bake element at 208/240V, and with the broil element in series across a 120V circuit, powers the inside broil element at 70V and the outside broil element at 50V.

Dual Fuel Convection Bake

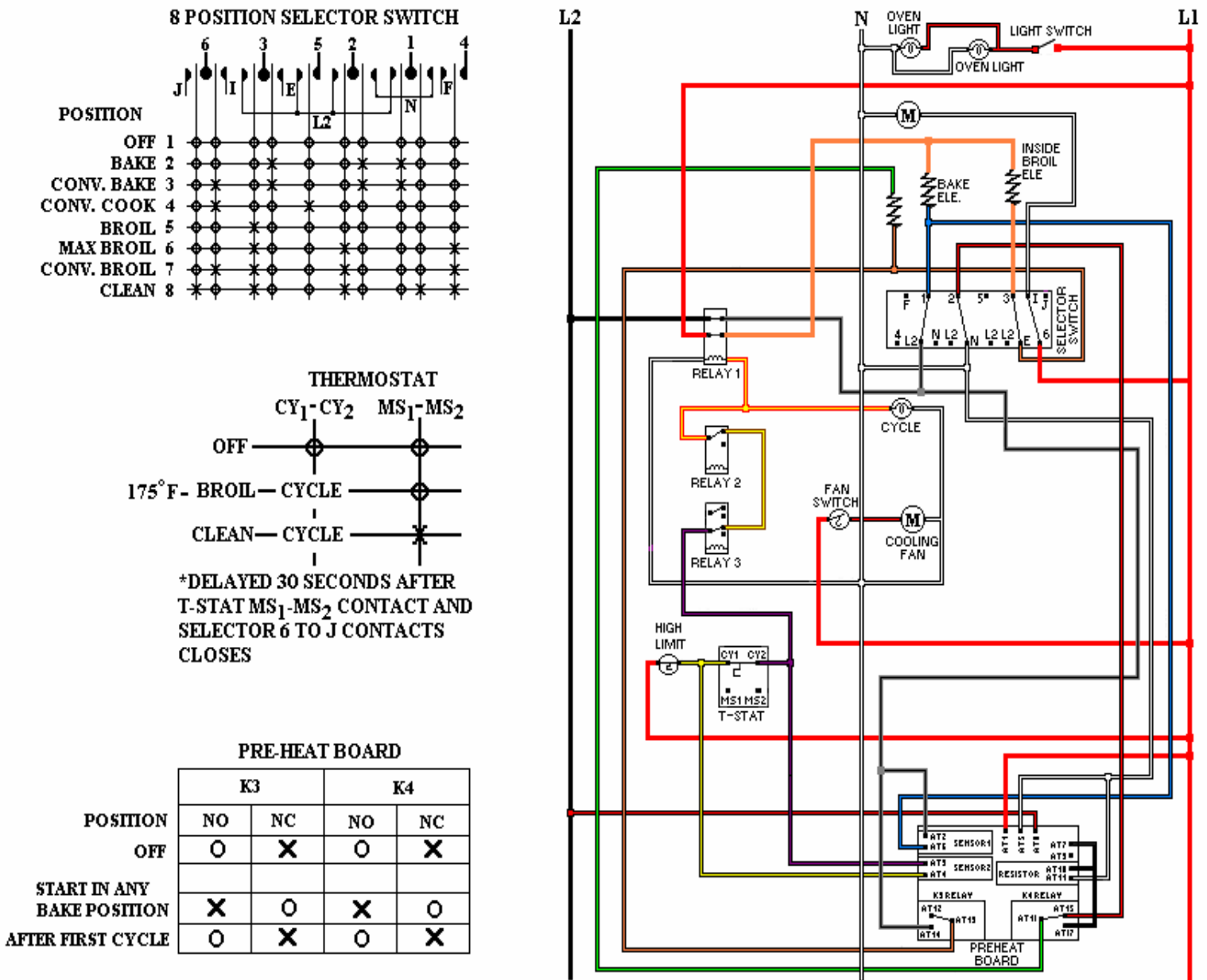

Selector in “convection bake” position closes selector switch 1-L1m 2-N, and 3-E and 6-I. 6-I powers the convection fan through L1 at 120V. The thermostat “on” closes switch Cy1-Cy2, which cycles with the oven temperature powering relay 1 and the oven cycle light. When relay 1 closes on the first cycle the broil elements are powered through relay K3 AT15-AT14 and relay K4 AT16-AT15 on the preheat board at 208/240V and the bake element is powered at 208/240V. When thermostat switch Cy1-Cy2 opens after first cycle relay K3 AT15-AT14 and relay K4 AT16-AT17 open. When thermostat switch Cy1-Cy2 closes for the second cycle relay 1 closes, it powers the bake element at 208/240V, and with the broil element in series across a 120V circuit, power the inside broil element at 70V and the outside broil element at 50V.

Dual Fuel Convection Cook

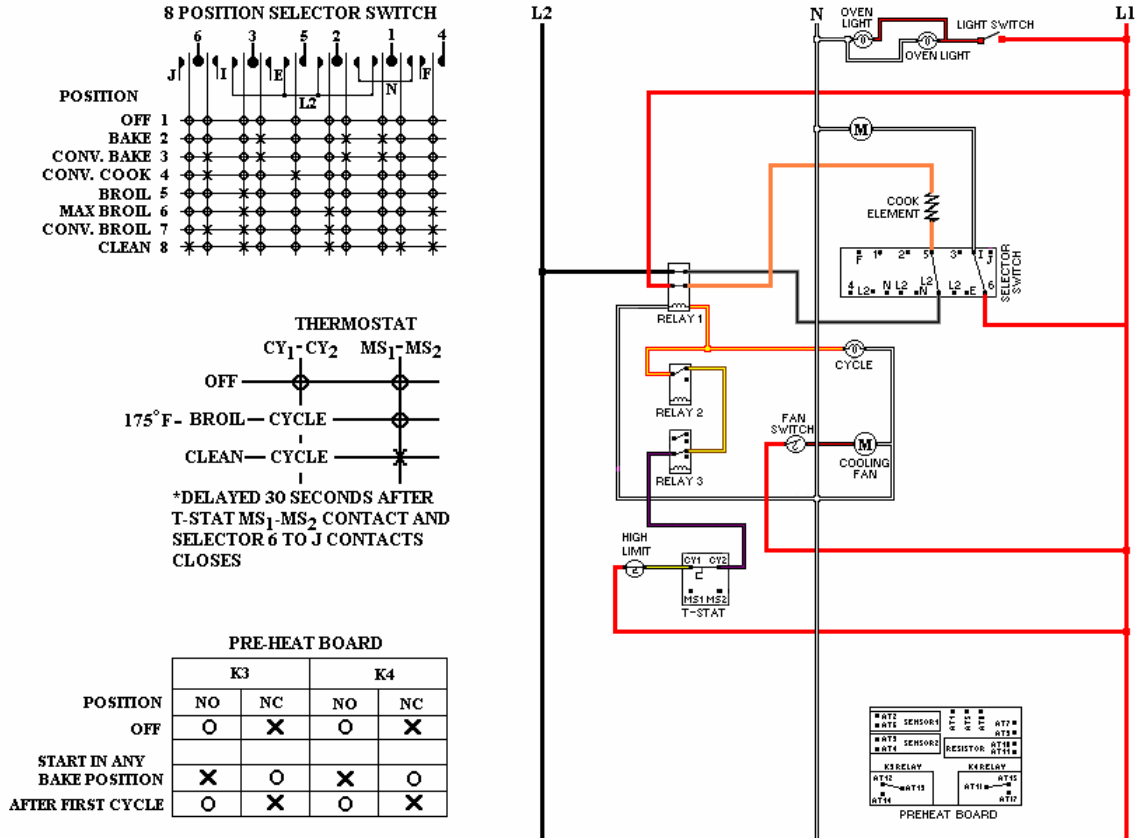

Selector in “Convection Cook” position closes switches 5-L2, and 6-1, 6-1 powers the convection fan through L1 at 120V. The thermostat closes switch CY1-Cy2, which cycles with the oven temperatures, powering relay1 and the oven cycle light. When relay 1 closes, it powers the convection element at 208/240V.

Dual Fuel Mini Broil

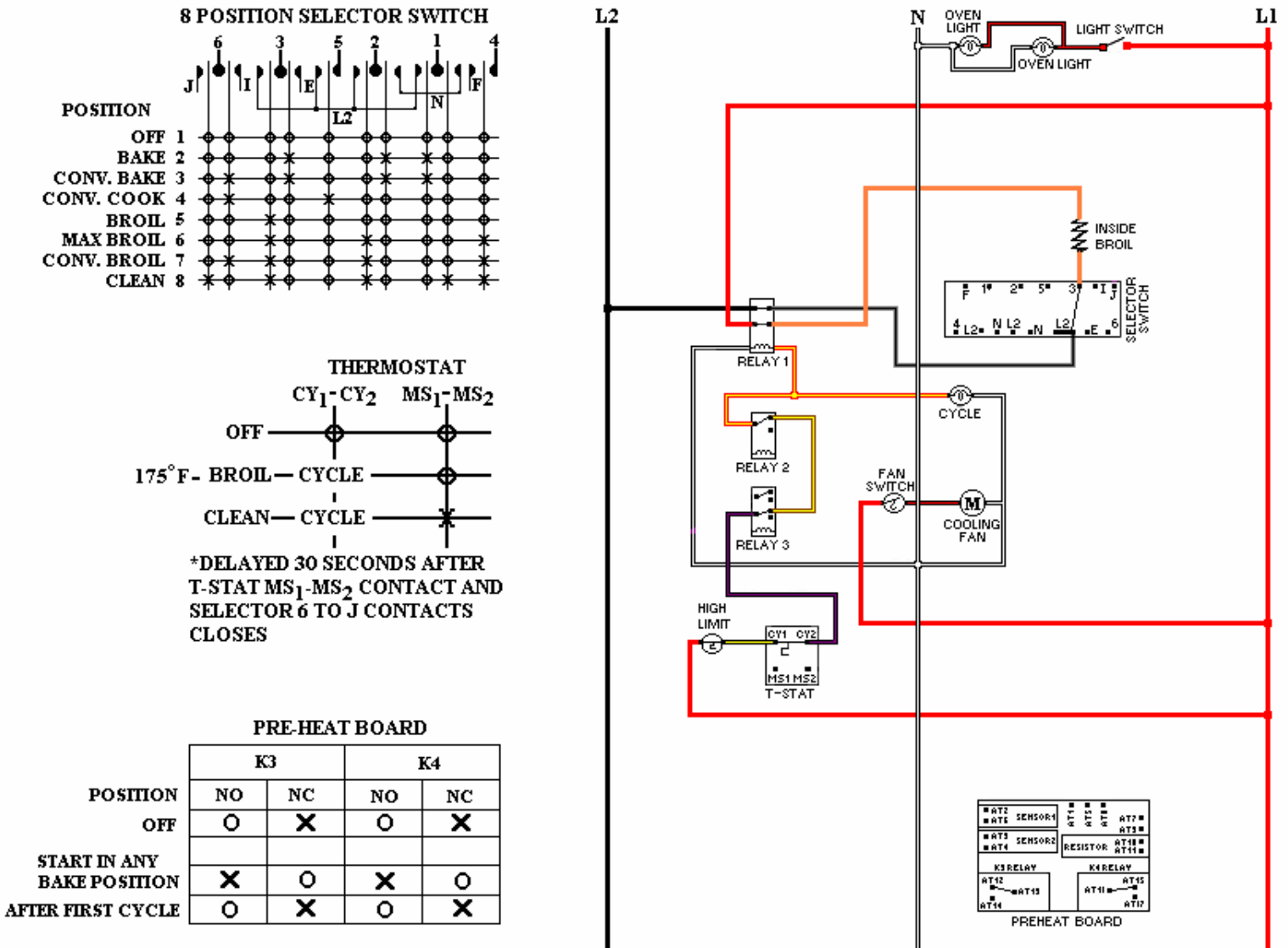

Selector in “Mini Broil” position closes switches 3-L2. The thermostat closes switch Cy1-Cy2, powering relay 1 and the oven cycle light. When relay closes, it powers the inside broil element at 208/140V.

Dual Fuel Maxi Broil

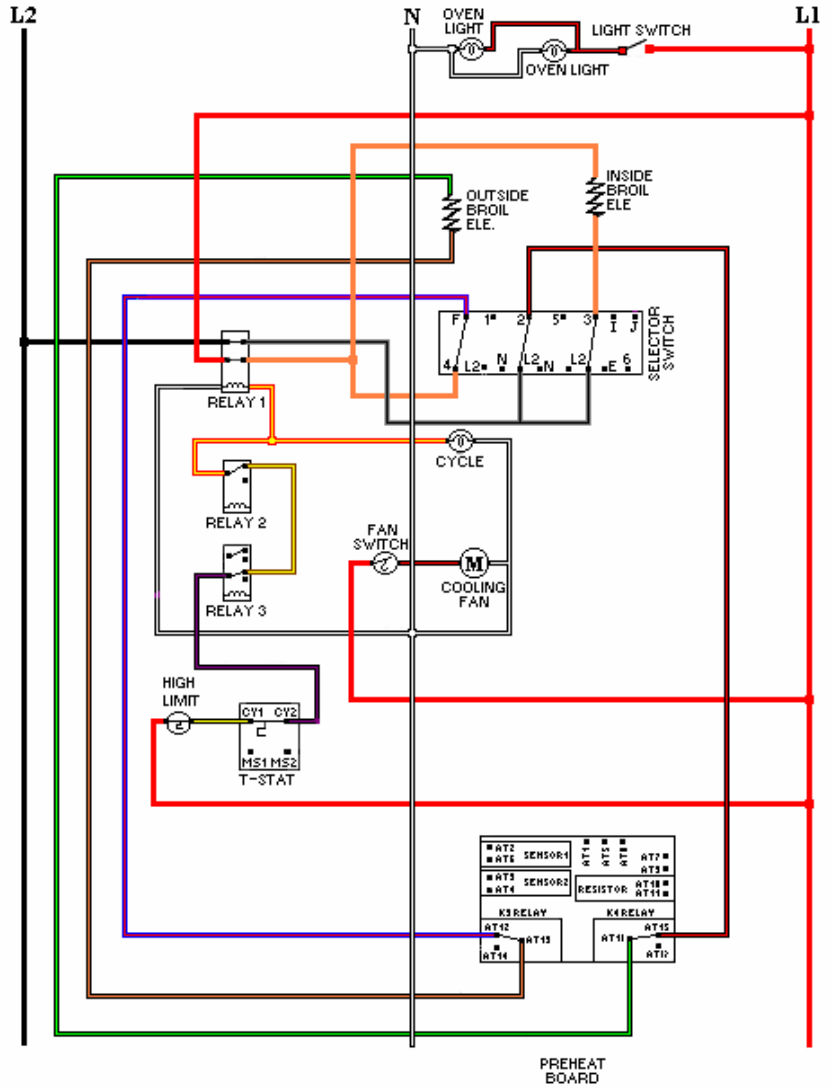
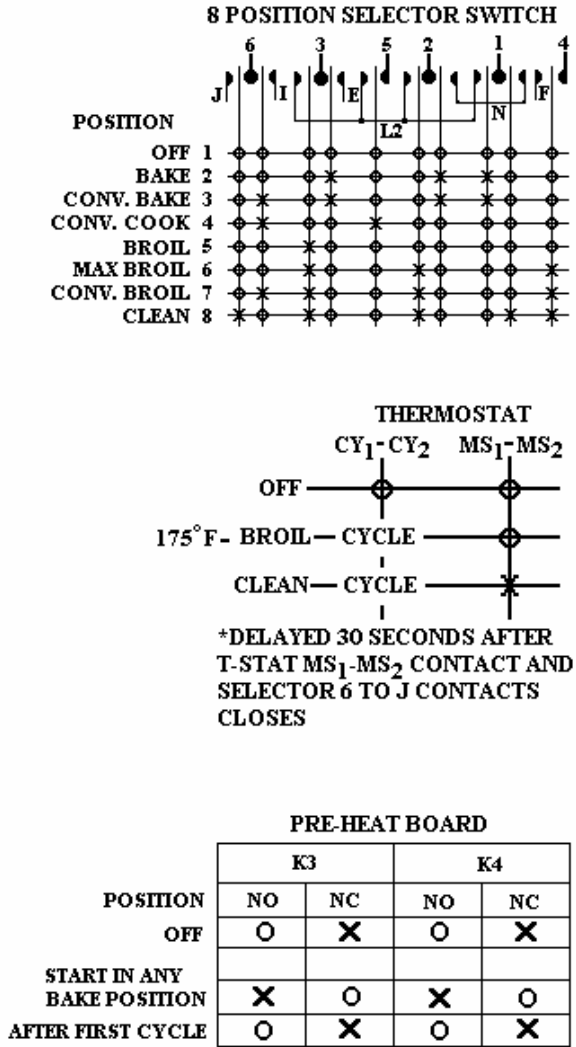

Selector in "Maxi Broil" position closes switches 4-F, 2-L2, and 3-L2. The thermostat closes switch Cy1-Cy2, which cycles with oven temperature, powering relay 1 and the oven cycle light. When relay 1 closes, it powers the inside broil element at 208/240V and the outside broil element at 208/240V.

Convection Broil

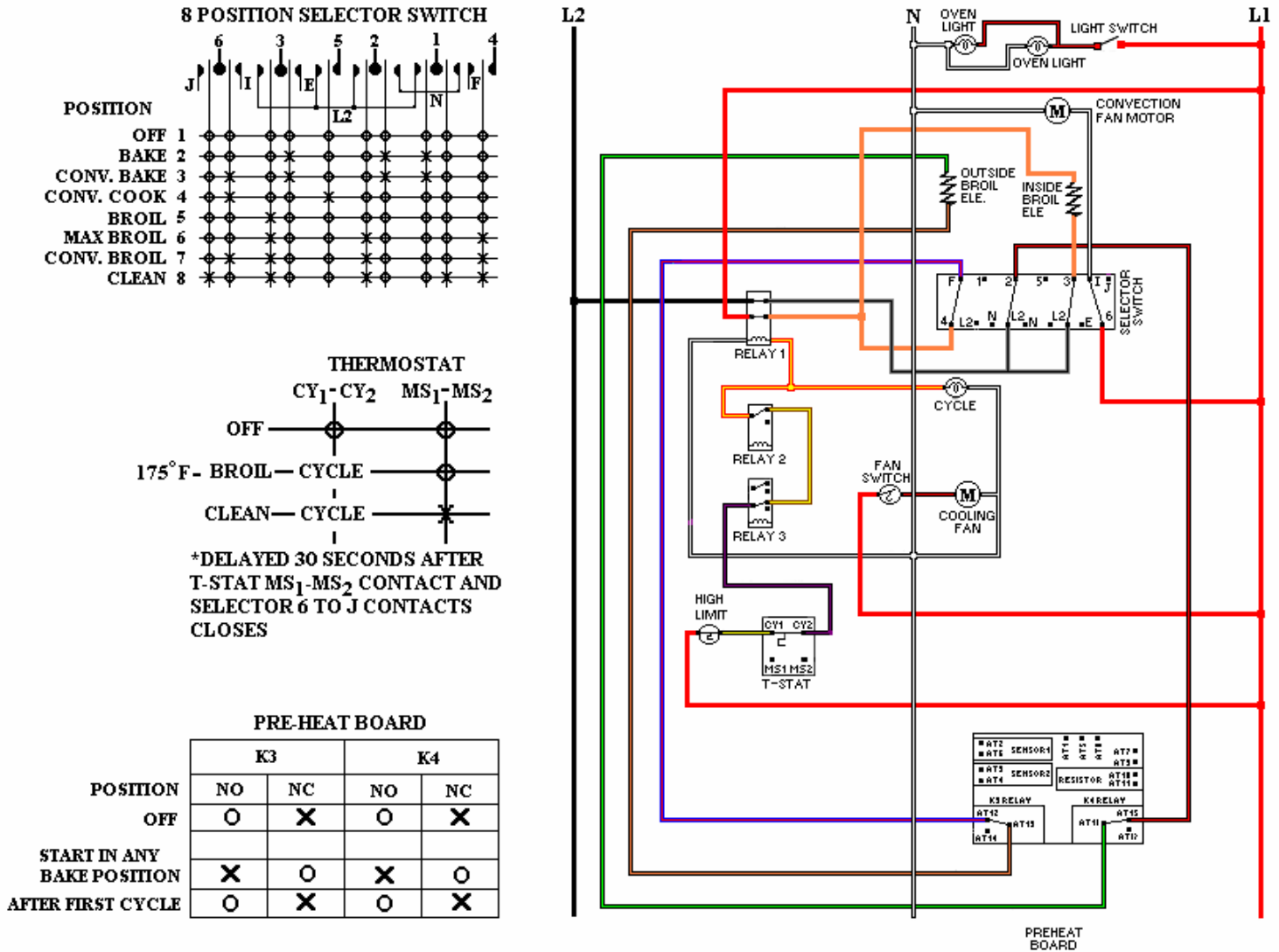

Selector in “Convection Broil” position closes switches 4-F, 2-L2, 3-L2, and 6-I. 6-I powers the convection fan through L1 at 120V. The thermostat closes switches Cy1-Cy2, which cycles with oven temperature, powering relay 1 and the oven cycle light. When relay 2 closes it powers the inside broil element at 208/240V and the outside broil element at 208/240V.

Dual Fuel Self-Clean

CLEAN DOOR LOCK BELOW 575°F ± 25°F

SELECTOR SWITCH closes Heating Element contacts 4 – F, 1 – N, 2 – L2, 3 – L2 and Door Lock Module / Timer contacts J – 6 energizing Relay #2.

THERMOSTAT CLEAN POSITION closes Thermostat cycling contacts 1 – 2 and normally open (N) – common © energizing Relay #3.

RELAY #3 turns on the clean indicator Light and energizes Door Lock Module / Timer (PC board) Relays LS1 – L1 and LS2 – M1, also supplying 120VAC to SEL on the PC board.

RELAYS LS1 and LS2 turns the door Lock Motor on through the Auto Reset Thermostat contacts 2 – 1.

DOOR LOCK MOTOR rotates opening SW1 and closing SW3.

DOOR LOCK SWITCH #2 completes the circuit to sensor #3 on the PC board. After 10 seconds LS1 – M1 opens, stopping the Door Lock motion.

DOOR LOCK SWITCH #3 closes T1 – T2 and T3 – T4 energizing Power Relay #1 and the cooling Fan. Closing Power Relay #1's contacts supplies 240VAC to both Broil Elements and 120vac to the Bake Element.

CLEAN DOOR LOCK ABOVE 575°F ± 25°F

AUTO RESET THERMOSTAT switches to contacts 1 – 3 turning on the Door Lock indicator Light and disables the Door Lock Motor circuit.

CLEAN TEMPERATURE (875°F) REACHED

DOOR LOCK MODULE / TIMER opens T3 – T4 and T1 – T2 turning off the cooling Fan, now powered by the Fan Limit Switch when needed, and opens the circuit to the Power Relay #1 disabling the Heating Elements.

FINAL BELOW 575°F ± 25°F

AUTO RESET THERMOSTAT switches to contacts 1 – 2, turning off the Door Lock Motor circuit through Door Lock Motor / Time Relay LS2 – M1. Door Lock Motor operates until 2 seconds after sensor 4 is signaled by VC that the Door Lock switch SW1 has been closed mechanically by the Door Lock Bolt. The Door Lock / Timer switches LS2 – M1 and LS2 – L1 open and the timer resets.

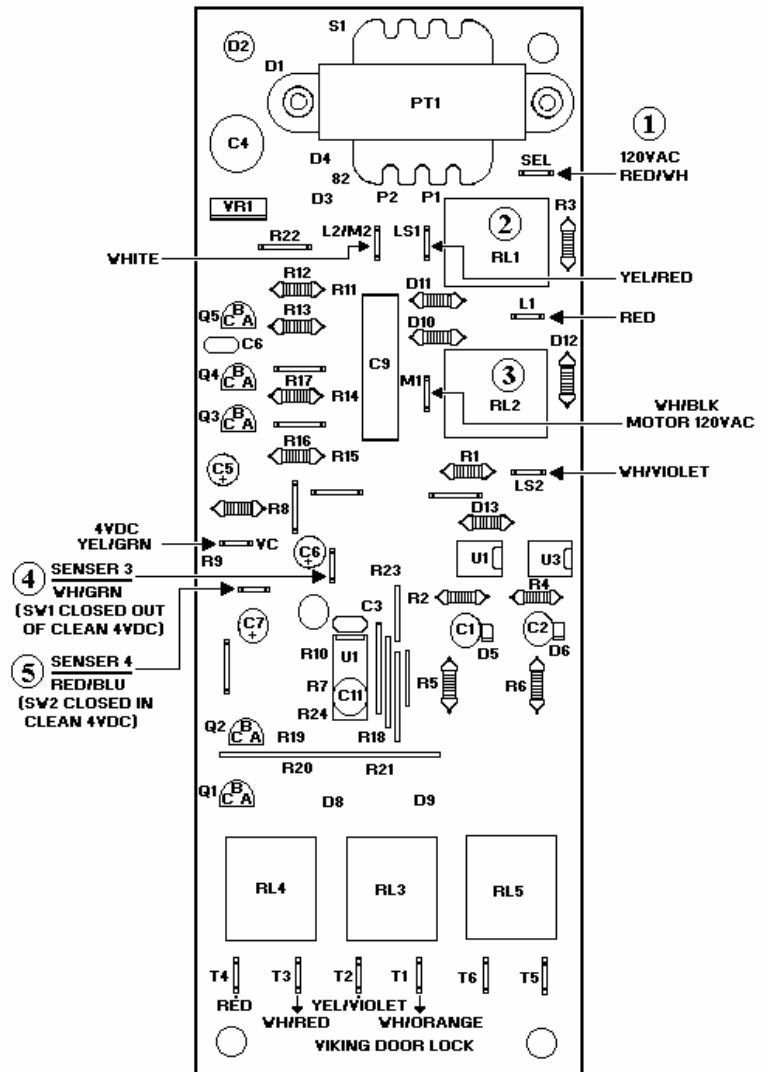

CONTROL CIRCUIT BOARD

Dual Fuel Self Clean Initiate Until Door Lock

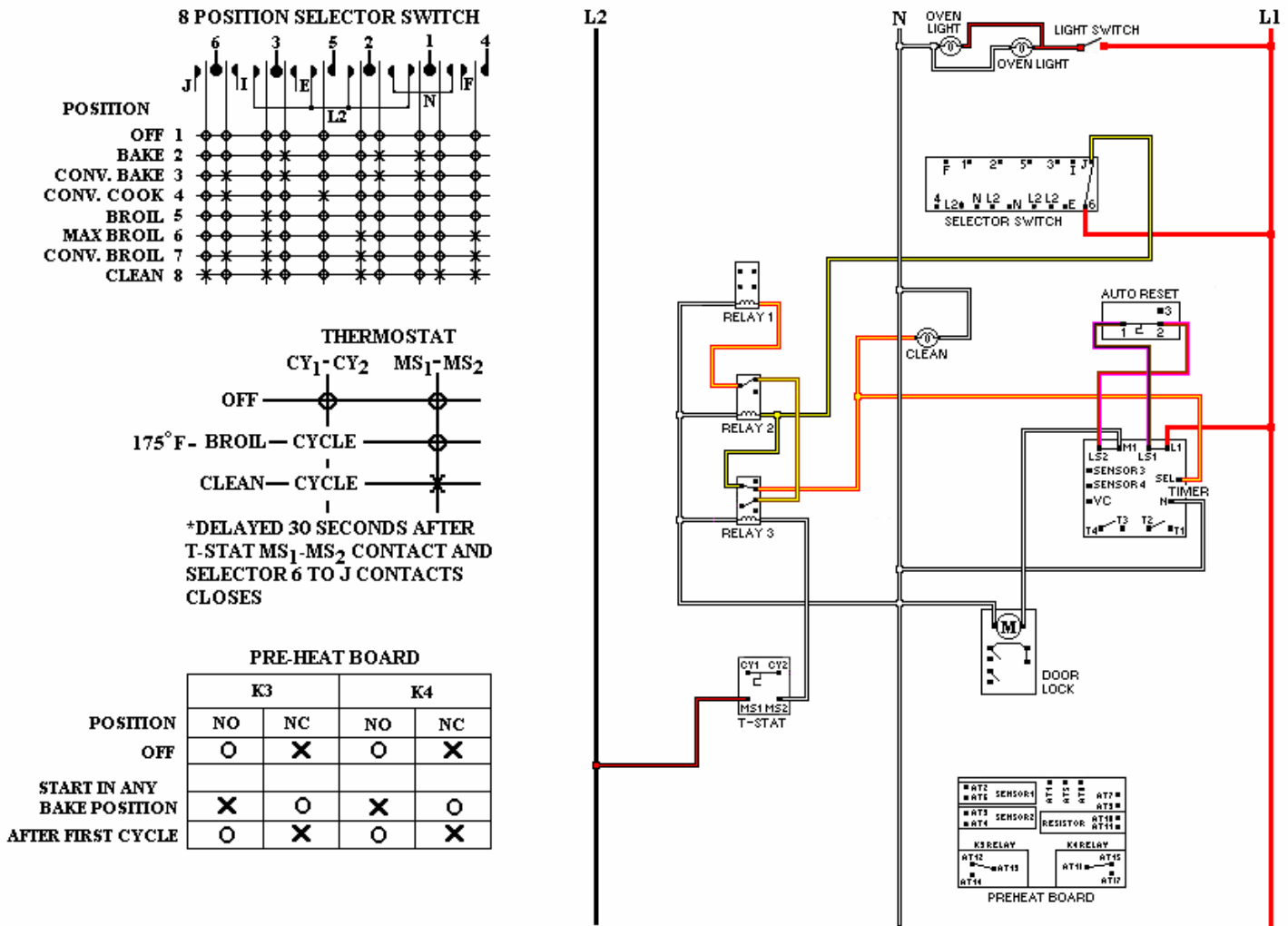

Selector in “Clean” position closes heating elements circuits 4-F, 1-N, 2-L2, 3-L2 and door lock module/timer circuit J-6 switches relay 2. Thermostat clean position closes the cycle switch and thermostat clean switch, which switches relay #3. switching relay 3 allows circuit J-6 to turn on the clean indicator light and enable the door lock module/timer which closes relays LS1-L1 and LS2-M1. This powers the door lock motor until 10 seconds after sensor 3 is signaled by VC that door lock switch SW2 has been closed mechanically (along with SW3) by the door lock blot.

Dual Fuel Clean Door Lock Below 575° F ± 25° F

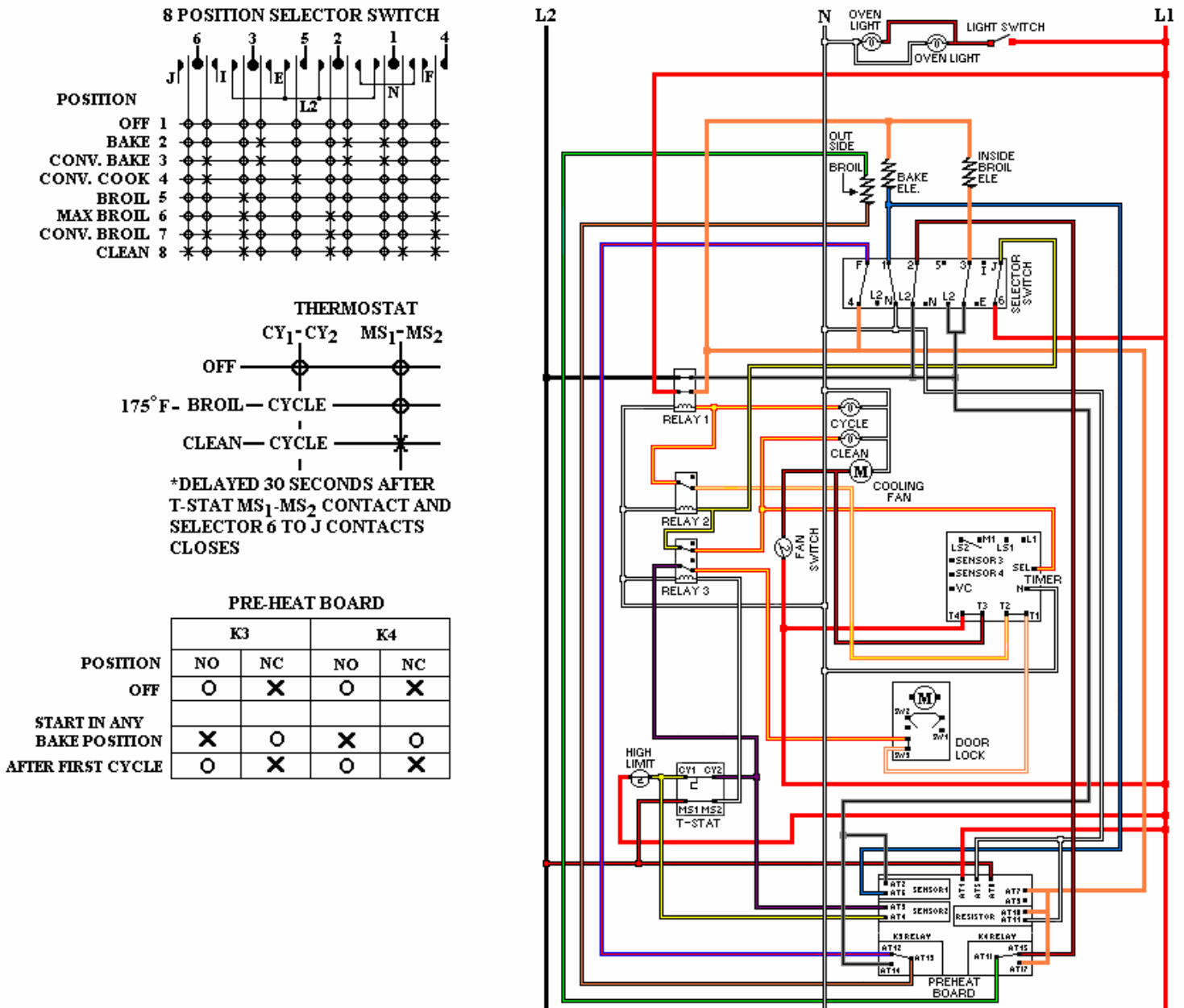

10 seconds after the signal to sensor 3, switch LS2-M1 is opened, stopping the door lock motion and switches T1-T2 and T3-T4 which switches relay 1, powering the cooling fan, which closes relay 1 powering the inside and outside broil elements at 208/240V and the bake element at 120V.

Dual Fuel Clean Door Lock Above 575° F ± 25° F

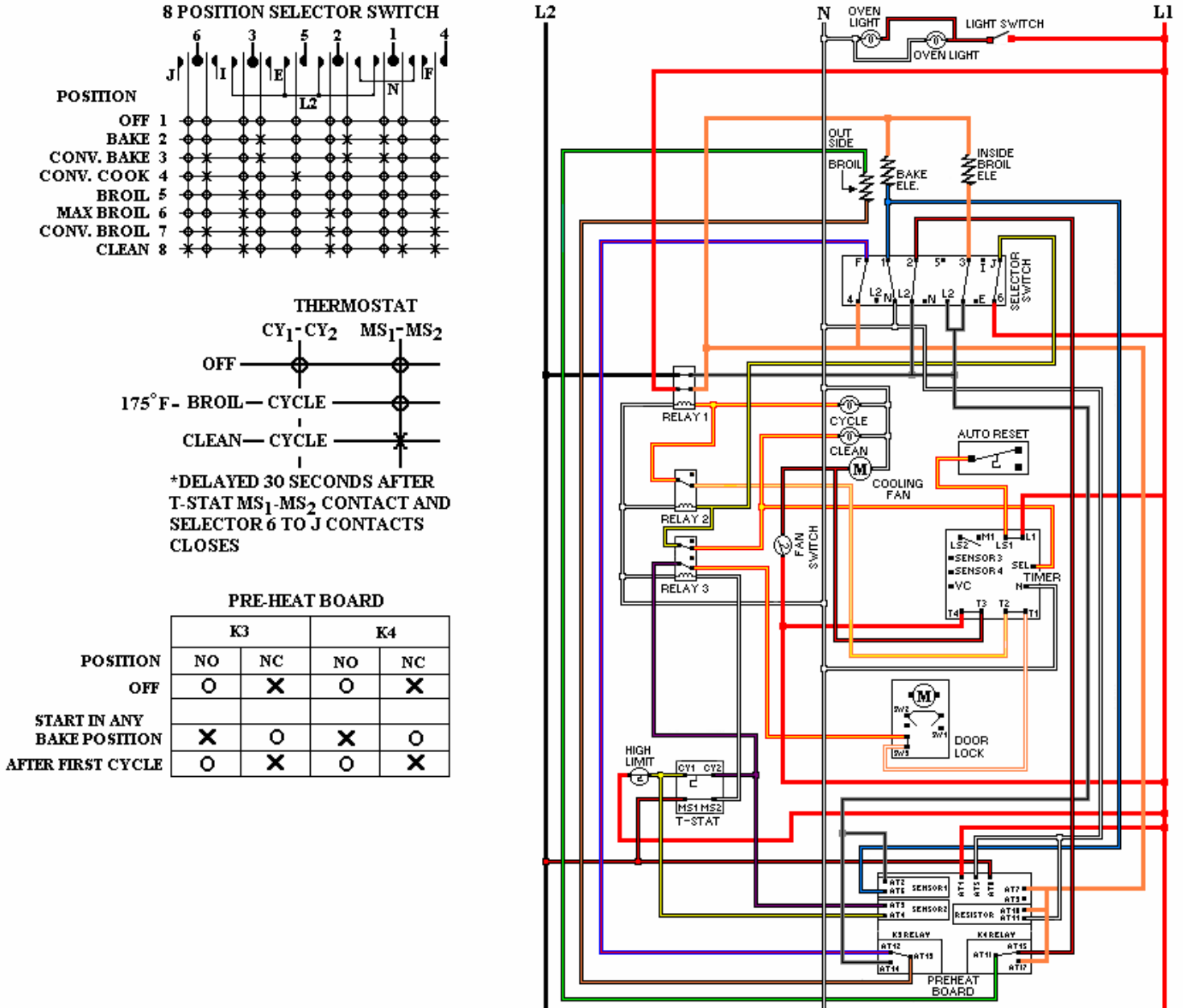

Auto reset switches to 1-3 which turns door lock indicator on an disables door lock motor circuit.

Dual Fuel Clean Finished Door Lock Below 575° F ±25° F

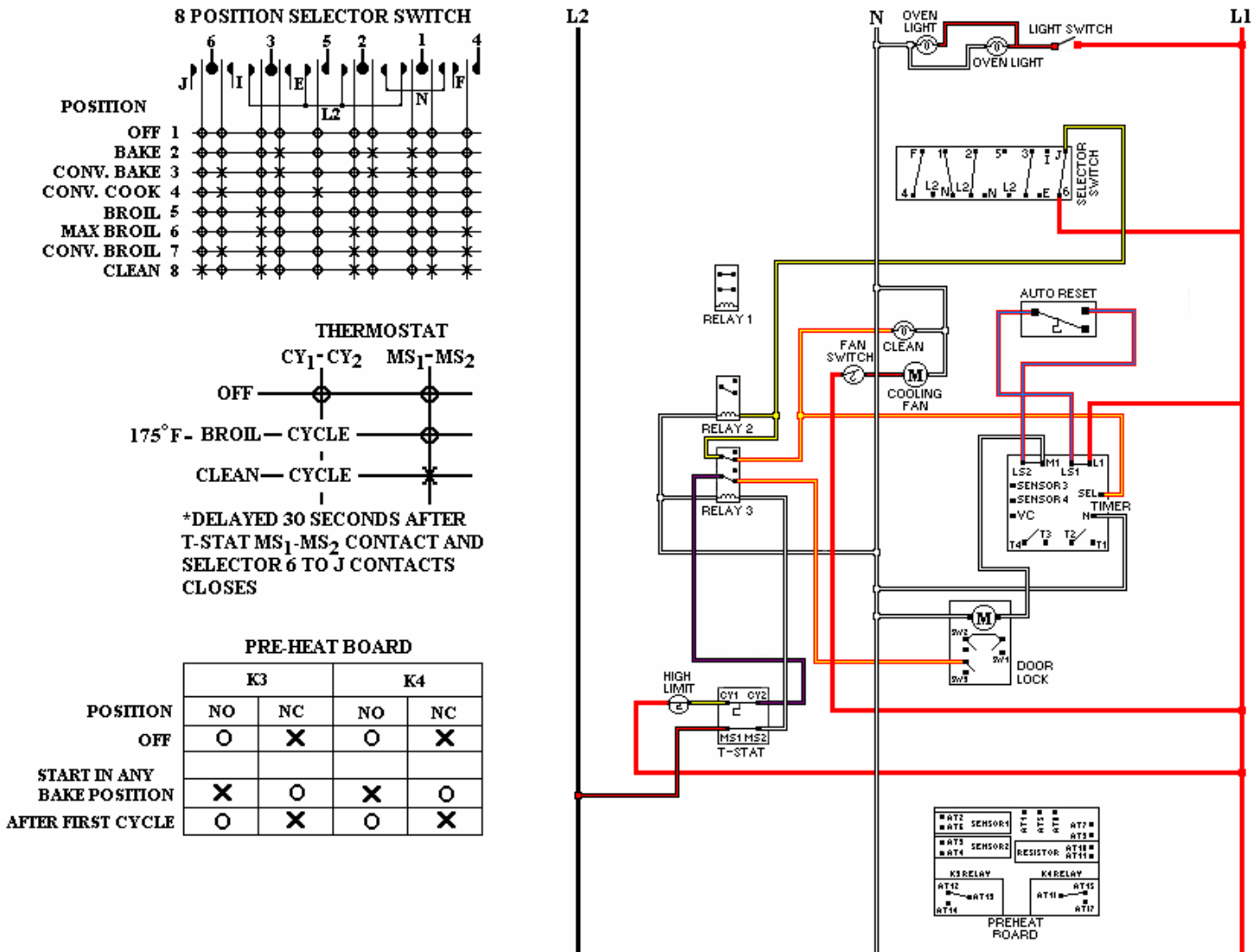

Auto reset switches 1-2 closed allowing the door lock motor to operate and turn the door lock light off. The door lock motor operates until 2 seconds after sensor 4 is signaled by VC that the door lock/timer switches LS2-M1 and LS1-L1 open and the timer resets.

INSTALLATION INSTRUCTION
For
PREHEAT CONTROL BOARD
For
MODEL VDSC

- STEP1: TURN OFF POWER TO THE RANGE.
- STEP2: REMOVE GRATES, GRATE SUPPORTS, AND CONTROL PANEL.
- STEP3: INSTALL CONTROL BOARD ON THE MOUNTING BRACKET USING STANDOFFS AS SHOWN IN FIGURE #1.
- STEP4: WIRE NEW CONTROL BOARD ACCORDING TO THE POINT-TO-POINT DIAGRAM AND BLOCK DIAGRAM ATTACHED. ROUTING WIRES AS SHOWN IN FIGURE #2.
- STEP5: INSTLL CONTROL BOARD MOUNTING BRACKET, USING SELF TAPPING SCREWS, ON THE RIGHT HAND TOP BURNER SUPPORT BRACKET AS SHOWN IN FIGURE #2.
- STEP6: INSTLL CONTROL BOARD COVER AS SHOWN IN FIGURE #3.
- STEP7: REPLACE GRATE SUPPORTS, GRATES, AND CONTROL PANEL. RESTORE POWER TO THE RANGE AND TEST UNIT FOR OPERATION.

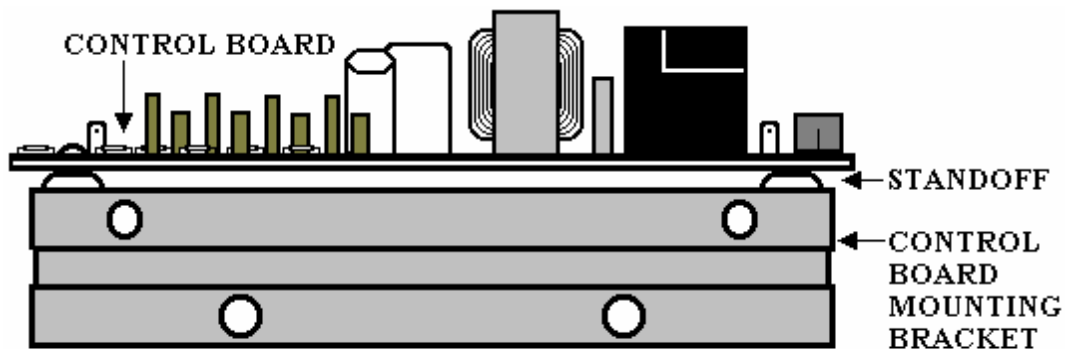

FIGURE #1

VEDO Double Ovens Pre-heat Board Kit G5007602
VESO Single Oven Pre-heat Board Kit G5007603
DEDO Double Oven Pre-heat Board Kit G5007604
DESO Single Oven Pre-heat Board Kit G5007605
Dual Fuel Ranges Oven Pre-heat Board Kit G5007606
VESC Oven Pre-heat Board Kit G50076007

VDSC G5007606

RED	AT1 on control board to Selector position 6 (leave existing Red wire attached to Selector using the jumper connector on the wire from the preheat control board).
GRAY	Relay K3 position N/O on the control board to position AT2 on the control board to Selector position L2 (leave existing Gray wire attached to Selector using the jumper connector on the wire from the preheat control board).
ORANGE	Relay K4 position N/O on the control board AT7 on the control board to AT10 on the control board to Selector position 4 (leave existing Orange wire attached to Selector using the jumper connector on the wire from the preheat board).
WHITE	AT11 on the control board to AT5 on the control board to Selector position N (leave existing White wire attached to selector using the jumper connector on the wire from the preheat control board).
WHITE/BLUE	AT6 on the control board to Selector position 1 (leave existing White/Blue wire attached to selector using the jumper connector on the wire from the preheat control board).
WHITE/RED	Relay K4 position N/C to Selector position 2 (remove yellow/Green from the Selector).
RED/BLUE	Relay K3 position N/C to Selector position F (remove White/Orange from the Selector).
YELLOW/GREEN	Relay K4 position common to Yellow/Green removed from Selector Position 2.
WHITE/ORANGE	Relay K3 position common to White/Orange removed from Selector position F.
WHITE/VIOLET	AT3 on the control board to thermostat position 1 (leave existing White/Violet wire attached to the thermostat using the jumper connector on the wire from the preheat control board).
YELLOW	AT4 on the control board to thermostat position 2 (leave existing Yellow wire attached to the thermostat using the jumper connector on the wire from the preheat control board).
RED/BLACK	AT8 on the control board to thermostat position 3 (leave existing Red/Black wire attached to the thermostat using the jumper connector on the wire from the preheat control board).

PREHEAT CONTROL VDSC

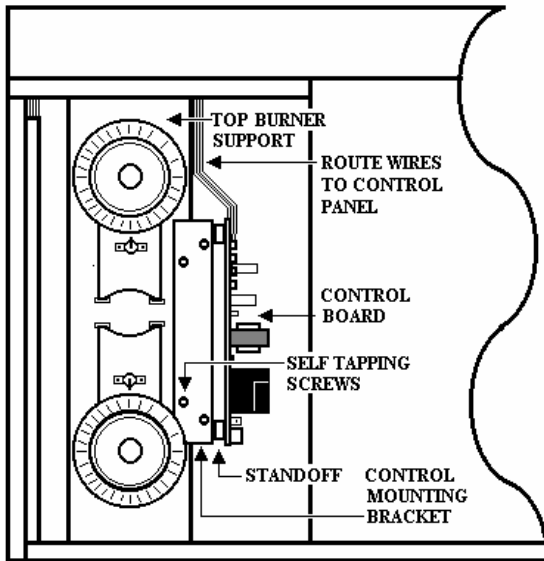

FIGURE #2

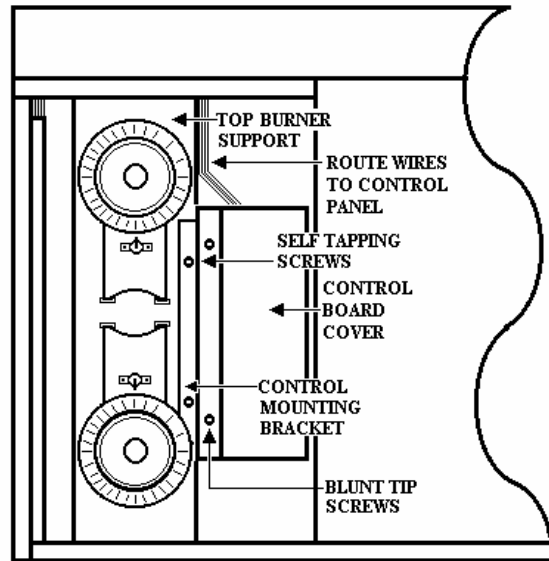

FIGURE #3

VDSC OVEN CONTROL

